

## OPUS III ezRide-22

### 32 Channel GPS / AGPS and 2 Channel SBAS Receiver

eMD3622F/OPUS III ezRide-22 is a high-sensitivity, complete GPS/AGPS receiver module that combines a hardware measurement platform with eRide's powerful navigation software integrated onto ARM7TDMI® microprocessor. It delivers fast, accurate positioning data in challenging locations like indoor environments and deep urban canyons.

eMD3622F is based on OPUS III technology and includes the OPUS IIIez BB IC and the Prelude III RF Receiver IC, a TCXO, two SAW filters and various matching and peripheral components in a small form factor. It is your complete GPS/AGPS solution with only an external GPS antenna and power supply required

eMD3622F has been engineered specifically for automotive applications such as Car Navigation Devices and Fleet Management, where performance, time to market and ease of integration are prime considerations.

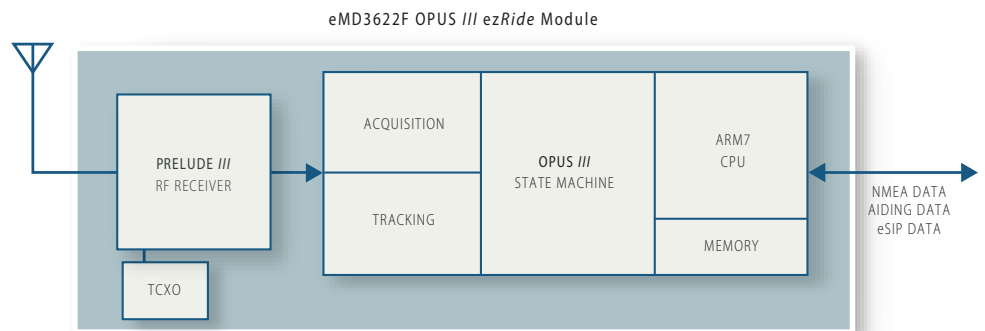

Figure 1: Block Diagram

### Features

- Supports GPS L-band C/A code channels and 2 additional dedicated WAAS channels for enhanced accuracy
- High indoor sensitivity of -161 dBm achieved utilizing 44,000 effective correlators (both in acquisition & tracking mode)
- Complete Autonomous GPS mode and Assisted GPS mode for Plug and Play solutions. Assisted-GPS Navigation software already embedded into eMD3622F
- Fast TTFF of typically < 1s in hot start condition, outdoor, and 33s from cold start condition
- Accuracy of 1.3 m outdoor and 12.5 m indoor typical with live-sky measurements
- Small 22 x 22 mm footprint for SMD compact designs
- User interface via a simple bidirectional serial port, 1 Hz update rate
- 3.0 to 3.6 V supply voltage

### Target Applications

- Car Navigation Devices
- Fleet Management/Tracking
- Personal Navigation Devices



## Content List

Tables	4-5
Figures	5
Version History	5
<b>1 Introduction</b>	<b>6</b>
1.1 Product Features	7
1.2 Block Level Diagram	8
<b>2 Functional Description</b>	<b>8</b>
2.1 Architecture	8
2.2 Boot-Up Selection	9
2.3 Module Control and Communications	9
2.4 Reset	9
2.5 Usage Modes	9
2.5.1 Autonomous Mode	10
2.5.2 Assisted Mode	10
2.6 Real Time Clock	11
2.7 Power Supplies	11
2.8 Peripherals	11
2.8.1 Time Differential	11
2.8.2 Pulse Per Second Signal	12
2.8.3 Frequency Differential	12
<b>3 General Performance</b>	<b>13</b>
3.1 Performance Summary	13
3.2 Time to First Fix and Sensitivity	14
3.3 Static Position Accuracy	15
<b>4 Electrical Characteristics</b>	<b>17</b>
4.1 Absolute Maximum Ratings	17
4.2 Electrical Specifications	17
4.3 Device Terminal Descriptions	19
4.3.1 GPS Antenna Input - ANT	19
4.3.2 Serial Port#1 Interface Input/Output – TXD, RXD	19



# OPUS III ezRide-22 Datasheet

## 32 Channel GPS / AGPS and 2 Channel SBAS Receiver

Part# eMD3622F  
October 25, 2007  
eDS-3622F0001-00B

4.3.3	Pulse Per Second Signal Output - PPS	19
4.3.4	GPS Receiver On, Off, and Standby Selection – ON/OFF/SBY	19
4.3.5	External Reset – NRST	20
4.3.6	JTAG Interface I/O's – TMS, TDO, TDI, TCK, TRSTn	20
4.3.7	Power Supplies	20
4.3.7.1	VCC	20
4.3.7.2	VBK	20
4.3.7.3	VANT	20
4.3.7.4	VCOR and VCOR_EN, VCOR_SEL	20
4.3.8	Frequency Differential Inputs – VCOCLK, VCOTRIG	21
4.3.9	Time Differential Input - EPPS	21
4.3.10	Frequency Generator Output – FG2CLK	21
4.3.11	General Purpose I/O's – GPIO[5:4]	21
4.3.12	Serial Port#2 Interface Input/Output – TX2/SDO/SDA, RX2/SDI, SCLK	21
4.3.13	Test Mode Selection Input – PTMODE	21
<b>5</b>	<b>Mechanical Specifications, Pining</b>	<b>22</b>
5.1	Package Outline	22
5.2	Pin Description	23
5.2.1	Pin List	23
5.2.2	Pin Assignment	24
5.3	Marking Description	24
5.4	Recommended Layout	25
<b>6</b>	<b>Software Specifications</b>	<b>25</b>
6.1	NMEA and ESIP - eRide Serial Communications Interface Protocol	25
6.1.1	NMEA Standard Output Messages	25
6.1.2	eSIP Proprietary Input and Output Messages	26
6.2	Principles of Operation	26
6.2.1	Power Modes	26
6.2.1.1	Mode 0 – OFF & Mode 1 – RTC	27
6.2.1.2	Mode 2 – Stand-By	28
6.2.1.3	Mode 3 - MCU	28
6.2.1.4	Mode 4 - GPS	28



# OPUS III ezRide-22 Datasheet

## 32 Channel GPS / AGPS and 2 Channel SBAS Receiver

Part# eMD3622F  
October 25, 2007  
eDS-3622F0001-00B

6.2.1.5	Power Up	28
6.2.1.6	Power Down	28
6.2.1.7	Cold Wake-Up, Cold Wake-Up Sources	28
6.2.1.8	Shut Down GPS	29
6.2.1.9	Start Up GPS	29
6.2.1.10	Stand By	29
6.2.2	Data Interface	29
6.2.2.1	ON/OFF/SBY	29
6.2.2.2	RXD, TXD - Serial Receive and Transmit Data of UART1	30
6.2.2.3	Other Data Interface	30
6.2.3	GPS Data Back-Up	30
<b>7</b>	<b>Application Information</b>	<b>30</b>
7.1	Application Circuit, Low Cost GPS/A-GPS Receiver	30
7.2	Recommended GPS Antenna	31
<b>8</b>	<b>Environmental Specifications</b>	<b>31</b>
<b>9</b>	<b>Packing and Product Handling</b>	<b>32</b>
9.1	Carrier Tape and Reel Dimensions	32
9.2	Component Orientation for Tape and Reel	32
9.3	Packaging and Delivery	32
9.4	Reflow Profile	33
9.5	ESD Sensitivity	34
9.6	RoHS Compliance	34
<b>10</b>	<b>Ordering Information</b>	<b>35</b>
10.1	Worldwide Sales Offices	35

## Tables

Table 1:	Initial Aiding Configuration in Autonomous Mode	10
Table 2:	Absolute Maximum Ratings	17
Table 3:	Pin List	23-24
Table 4:	eMD3622F Power Modes	26
Table 5:	Recommended Antenna Specifications	31



# OPUS III ezRide-22 Datasheet

## 32 Channel GPS / AGPS and 2 Channel SBAS Receiver

Part# eMD3622F  
 October 25, 2007  
 eDS-3622F0001-00B

Table 6:	Environmental Specifications	31
Table 7:	Pb-free Process - Package Peak Reflow Temperatures	33

### Figures

Figure 1:	Block Diagram	1
Figure 2:	eMD3622F Block Diagram	8
Figure 3:	Cold Start Time to First Fix	14
Figure 4:	Hot Start Time to First Fix	14
Figure 5:	Cold Start First Fix Position Error	15
Figure 6:	Hot Start First Fix Position Error	15
Figure 7:	First Fix Outdoor and Indoor Position Accuracy	16
Figure 8:	PPS Timing	19
Figure 9:	Pin Location (Top View)	22
Figure 10:	Shield Case Dimensions	22
Figure 11:	Pin Assignment (Top View)	24
Figure 12:	Marking	24
Figure 13:	Recommended Footprint Pad Size	25
Figure 14:	Power Modes Transition Diagram	27
Figure 15:	Low Cost GPS/A-GPS Receiver	30
Figure 16:	Alternative Back-Up Supply Schemes	31

### Version History

Version	Contents Change	Date
00A	Initial Release	2007.10.11
00B	Fixed text in section 3.1, 3.2, & 3.3. Placed cleaner images throughout datasheet	2007.10.25

## 1 Introduction

eMD3622F/OPUS III ezRide-22 is a high-sensitivity, complete GPS/AGPS receiver module that combines a hardware measurement platform with eRide's powerful navigation software integrated onto ARM 7 microprocessor. It delivers fast, accurate positioning data in challenging locations like indoor environments and deep urban canyons. It is capable of working indoors by acquiring and tracking signals down to -161 dBm. It is a complete GPS/AGPS solution with only an external GPS antenna and power supply required.

eMD3622F is based on eRide's OPUS III technology and includes:

- ePV3600/OPUS IIIez BB IC
- OPUS III high performance GPS engine with 44,000 effective correlators
- ARM7TDMI-based MCU, with on-chip ROM and SRAM memories
- 1 UART + either 1 UART ,1 SPI, or 1 I2C serial ports
- Battery backed-up 32 Khz crystal oscillator, Real Time Counter, GPS Data SRAM
- GPIO's
- Embedded power management
- JTAG
- ePR3036/Prelude III RF Receiver IC
- Low IF (1.276 MHz) single conversion architecture
- On-chip 1.2 dB NF LNA, I/Q Mixers, Band-pass filters, 2-bit ADC, VCO, PLL
- 27.456 MHz TXCO
- Two SAW filters for improved blocking immunity and selectivity
- GPS antenna matching network



# OPUS III ezRide-22 Datasheet

## 32 Channel GPS / AGPS and 2 Channel SBAS Receiver

Part# eMD3622F  
October 25, 2007  
eDS-3622F0001-00B

### 1.1 Product Features

- Supports GPS L-band C/A code. 32 channel acquisition, 12 channel tracking, and 2 channel capable SBAS (EGNOS, WAAS and MSAS) for enhanced accuracy
- High indoor sensitivity of -161 dBm, achieved utilizing 44,000 effective correlators, both in acquisition under Hot Start conditions and in tracking mode. -146.5 dBm sensitivity in acquisition under Warm and Cold Start conditions
- Works in both complete Autonomous mode with (and/or) simple Assisted-GPS mode (A-GPS) for Plug and Play solutions. Assisted-GPS features provided by messages passed through the bidirectional eSIP port (requires a mobile network access)
- Fast Time To First Fix: Hot Start - < 1 sec typ outdoor (visible satellites with received power at -140 dBm or higher), < 15 sec typ indoor (all visible satellites with power levels at -153 dBm or lower); Warm Start - 33 sec typ @ -135 dBm; Cold Start: 34 sec typ @ -135 dBm
- Accuracy of 1.3 m outdoor and 12.5 m indoor typical with live-sky measurements
- Typical current consumption when tracking outdoor is 40 mA, 58 mA when tracking indoor and 62 mA during acquisition
- Small 22 x 22 mm foot-print total footprint for SMD compact designs
- User interface via a simple bidirectional serial port, 1 Hz update rate. Supports the industry standard NMEA 0183 v3.0 and the eRide's Serial Interface Protocol (eSIP). Communications over a programmable UART
- High blocking immunity and selectivity thanks to a double SAW architecture. Ideal for harsh environment such as automotive and handset.
- Supply voltage 3.0 to 3.6 V
- Battery backed-up Real Time Clock and GPS Data RAM to allow fast time to first fix in autonomous mode

### 1.2 Block Level Diagram

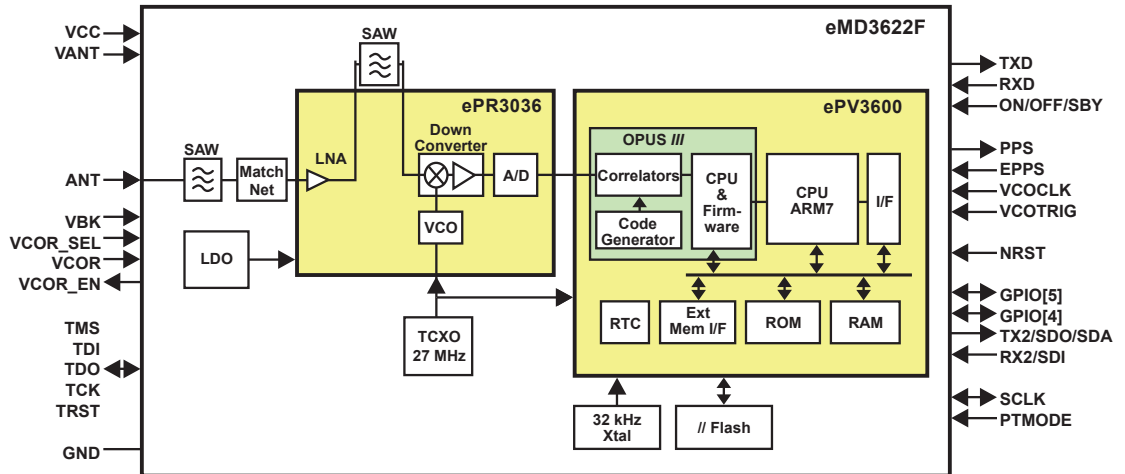

Figure 2: eMD3622F Block Diagram

## 2 Functional Description

### 2.1 Architecture

The heart of eMD3622F is the eRide's OPUS III GPS processing engine. This processing engine has 44,000 effective correlators available to either search 32 satellites at several time/frequency hypotheses or to search thousands of time/frequency hypotheses for a few satellites that are in view. The OPUS III DSP can track and decode simultaneously 12 satellites (channels) in addition to having 2 additional dedicated SBAS (EGNOS, WAAS and MSAS) channels. Search windows (time/frequency hypotheses) are configurable for each satellite.

This powerful engine works in combination with the eRide Opus software running on a ARM7TDMI-based MCU, with embedded ROM, SRAM, external memory interface to address on-board parallel FLASH memory, serial ports (UART's, SPI, I2C), GPIO's, timers, and other supporting peripherals.

The RF section is built around the eRide's ePR3036 RF Receiver IC, It's a low IF single down conversion circuit, with on-chip LNA, I/Q Mixers, Band-pass filters, 2-bit ADC, VCO, and PLL. Two SAW filters, the first one between the antenna input and the LNA, the second one before the down-converter mixer, provides the necessary blocking immunity and selectivity to operate in harsh environment, such as automotive and handset.



The system includes a battery backed-up Real Time Clock and Data module that is supplied by a separate power source whenever the main supply is turned Off. That feature allows fast time to first fix in autonomous mode.

eMD3622F master clock is derived from the on-board 27.456 MHz TCXO, which is also used as the reference clock for the RF PLL.

The baseband section of eMD3622F is supplied directly from the VCC pin, while the sensitive RF section is supplied by an on-board LDO.

In addition to the external NRST reset pin, eMD3622F has two type of reset. First, a power-on reset that monitors the main supply VCC. Second, a watchdog reset which will be activated in case of software failure.

eMD3622F only requires a passive GPS antenna.

## 2.2 Boot-Up Selection

For normal mode of operation, the PTMODE pin should be connected to VCC or remain not connected (n.c.). Other mode is not supported.

## 2.3 Module Control and Communications

After power-up the circuit will automatically start to operate as described in section 6.2.

## 2.4 Reset

eMD3622F has three reset mechanisms.

First, there is the NRST pin for external reset. NRST is an active low-level input. It is asserted asynchronously, but exit from reset is synchronized internally to the system clock.

Second, a power-on reset that monitors the main supply VCC. Whenever VCC level is or fall below a pre-defined threshold, the baseband circuit goes in reset state. The reset signal will be released whenever the VCC level is or rise above a pre-defined threshold.

Finally, a watchdog reset inside the embedded MCU will be activated in case of software failure.

## 2.5 Usage Modes

eMD3622F can operate both in autonomous and assisted GPS (A-GPS) mode.



### 2.5.1 Autonomous Mode

If no network/server connection is provided, eMD3622F will run as a stand alone autonomous GPS receiver. In this mode it is able to achieve fast “hot-start” performances and high sensitivity by storing previously collected information in battery backed-up memory and maintaining time information with its real time clock (RTC).

When starting in autonomous mode, eMD3622F will optimally utilize any previously stored information available in back-up memory and RTC time if available. The type and age of this information will determine the module’s initial “aiding configuration” as shown in Table 1.

Aiding Configurations	Approximate Time	Approximate Position	Current Ephemeris	Recent Almanac	ROM Almanac
Hot	<input checked="" type="checkbox"/>	<input checked="" type="checkbox"/>	<input checked="" type="checkbox"/>	<input checked="" type="checkbox"/>	<input checked="" type="checkbox"/>
Warm	<input checked="" type="checkbox"/>	<input checked="" type="checkbox"/>	<input type="checkbox"/>	<input checked="" type="checkbox"/>	<input checked="" type="checkbox"/>
Cold	<input type="checkbox"/>	<input type="checkbox"/>	<input type="checkbox"/>	<input checked="" type="checkbox"/>	<input checked="" type="checkbox"/>
Factory Cold	<input type="checkbox"/>	<input type="checkbox"/>	<input type="checkbox"/>	<input type="checkbox"/>	<input checked="" type="checkbox"/>
Simulator Cold	<input type="checkbox"/>	<input type="checkbox"/>	<input type="checkbox"/>	<input type="checkbox"/>	<input type="checkbox"/>

Table 1: Initial Aiding Configuration in Autonomous Mode

### 2.5.2 Assisted Mode

If a communications link is provided which allows the eMD3622F to communicate with eRide’s Symphony Aiding Server, it can then operate in assisted mode (A-GPS).

In this mode, eMD3622F will receive the following information from the server:

- Approximate current time
- Current Low Accuracy- and High Accuracy Satellite Models for all satellites
- Long Term Satellite Models (LTSM) for all satellites

This information will enable the receiver to achieve near hot-start performance. After a session with successful server communication, eMD3622F could be used in autonomous mode without having to collect ephemeris from the satellites for up to 7 days with the LTSM support.

## 2.6 Real Time Clock

eMD3622F has two built-in real time clock modes. While in GPS standby mode, it utilizes the accurate 27 MHz oscillator to maintain highly accurate time. While in Stand-By or RTC mode, it utilizes the module's low-power 32 kHz oscillator to maintain time.

When the GPS function is not needed, it is recommended to use the RTC mode to achieve the lowest possible power consumption while maintaining RTC time.

## 2.7 Power Supplies

eMD3622F can operate from a single VCC supply. It has embedded regulators to generate the necessary internal supplies. However, the internal regulator which supplies the GPS receiver core (ePV3600) can be bypassed by connecting VCOR\_SEL to VCC. In this case, eMD3622F needs an external 1.0 V voltage supply VCOR.

An embedded Real Time Counter as well as an on-board SRAM memory to store satellite model data are located in a battery backed up section of eMD3622F supplied by VBK. VBK must be turned ON whenever VCC is turned OFF for proper operation, otherwise these battery backed up data would be lost.

See chapter 4.3.7 for detailed information.

## 2.8 Peripherals

eMD3622F supports several advanced peripherals which can be used to improve performances.

### 2.8.1 Time Differential

The Time Differential peripheral (TimeDiff) allows the host application to provide a precise estimate of current time via an external pulse per second signal into the module's EPPS pin. eMD3622F then measures the time difference between its internal reference and the external pulse to adopt the appropriate GPS time estimate. TimeDiff allows a host application to provide a very precise time estimate (less than 1 ms uncertainty) that consequentially allows eMD3622F to quickly acquire signals in very weak signal conditions.

TimeDiff is currently not supported by the ezRide-22 software. Please contact your eRide sales representative for availability of software upgrade.



## 2.8.2 Pulse Per Second Signal

The ezRide-22's PPS pin provides a Pulse Per Second output signal that can be used to synchronize any external device with exact GPS time (~20 nano-seconds accuracy). The rising edge of the PPS signal is configured via eSIP commands to be synchronous with either the GPS second (Fine PPS), or the ezRide's internal millisecond counter (Coarse PPS).

Fine PPS mode uses an accurate GPS position to steer the sub millisecond error to the GPS second. It can be configured to output a pulse every second on the GPS second, or at any interval between 1 and 32 seconds.

Coarse PPS mode does not require a GPS position to start. The interval between pulses can be any millisecond value between 20 and 32,767.

PPS is currently not supported by the ezRide-22 software. Please contact your eRide sales representative for availability of software upgrade.

## 2.8.3 Frequency Differential

The Frequency Differential peripheral (FreqDiff) allows the host application to provide an external frequency reference, typically from a VCO, through the VCOCLK and VCOCLKEN pins. This enables the eMD3622F module to accurately estimate the drift of its local clock, and improve its GPS performance. Better frequency accuracy enables eMD3622F to generate faster TTFF by reducing the frequency search window in which the receiver searches for the satellites incoming frequency signal.

FreqDiff is currently not supported by the ezRide-22 software. Please contact your eRide sales representative for availability of software upgrade.



### 3 General Performance

#### 3.1 Performance Summary

<b>Receiver Type</b>	OPUS IIIez 32 Acquisition Channels 12 Tracking Channels 2 SBAS Channels L1, C/A Code 1 Hz Update Rate	
<b>Accuracy</b>	Outdoor <sup>1</sup> 1.3 m CEP	Indoor <sup>2</sup> 12.5 m CEP
<b>Time to First Fix (TTFF)<sup>3</sup></b>	Outdoor <sup>1</sup> Hot < 1 s Warm 33 s Cold 33 s	Indoor <sup>2</sup> 6 s N/A N/A
<b>Sensitivity<sup>3</sup></b>	Tracking Hot Acquisition Warm Acquisition Cold Acquisition	-161 dBm -161 dBm -146 dBm -145 dBm
<b>Operational Limits<sup>4</sup></b>	Altitude Velocity	18,000 m 515 m/s

- <sup>1</sup> Simulator test with all signals at -130 dBm with external LNA
- <sup>2</sup> Simulator test with all signals at -150 dBm with external LNA
- <sup>3</sup> Using external LNA
- <sup>4</sup> Based on the CoCom specification

### 3.2 Time to First Fix and Sensitivity

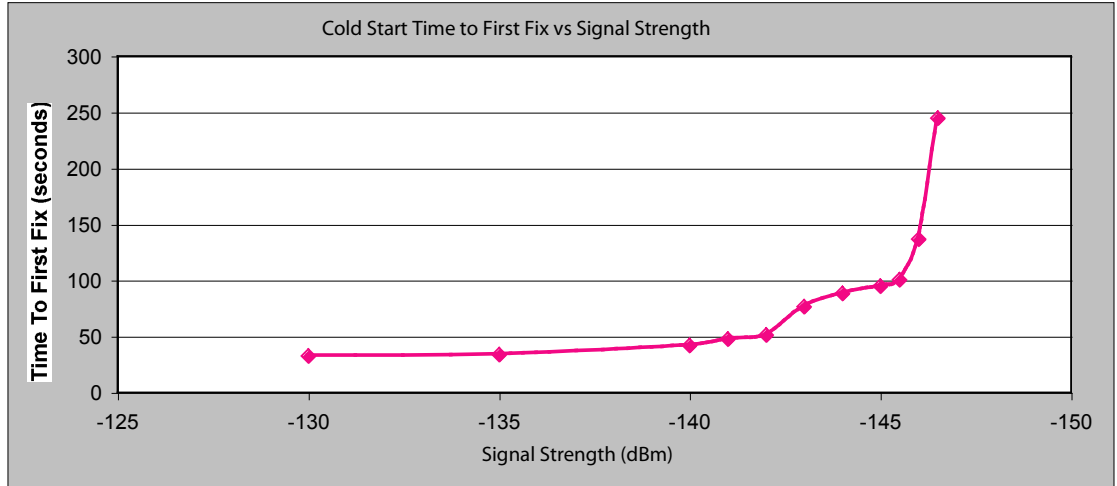

Figure 3: Cold Start Time to First Fix<sup>1</sup>

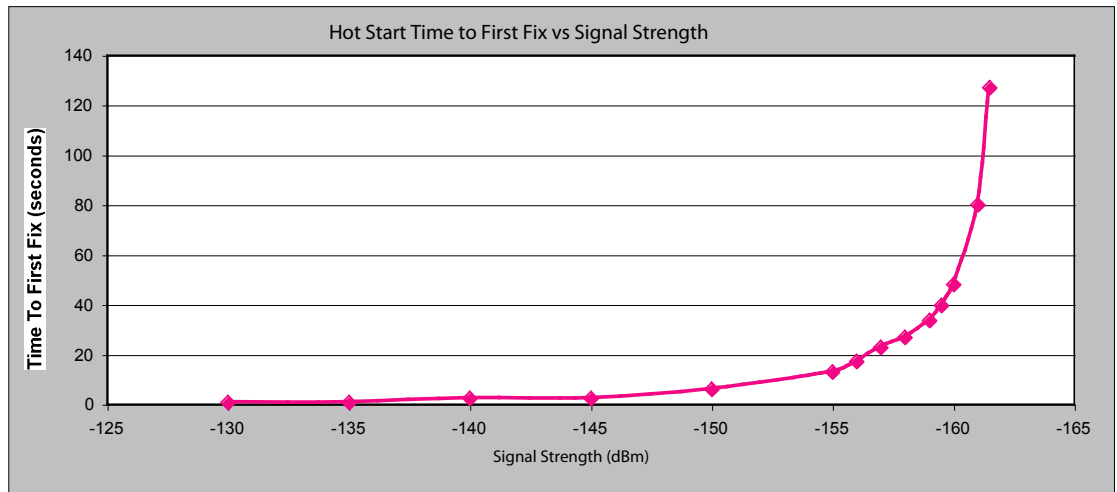

Figure 4: Hot Start Time to First Fix<sup>1</sup>

<sup>1</sup> Using external LNA (i.e. active antenna)

### 3.3 Static Position Accuracy

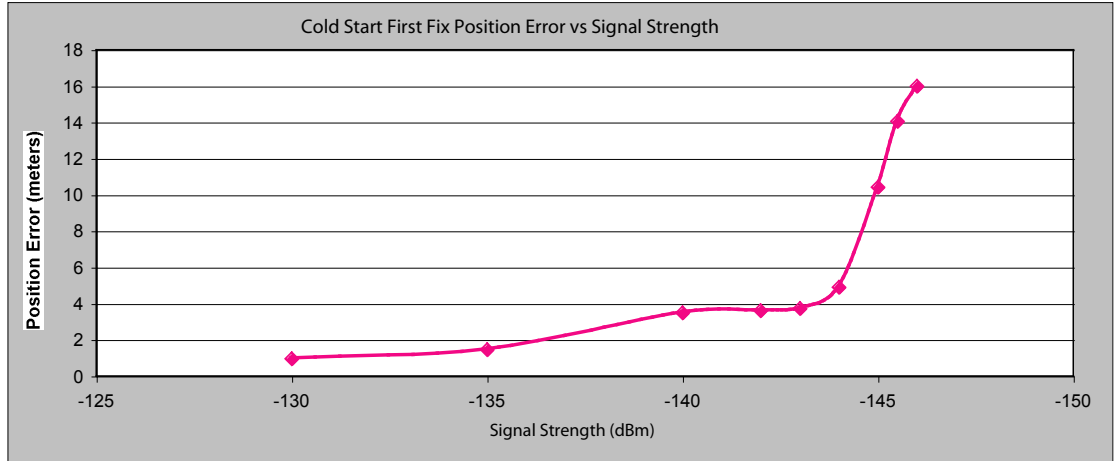

Figure 5: Cold Start First Fix Position Error<sup>1</sup>

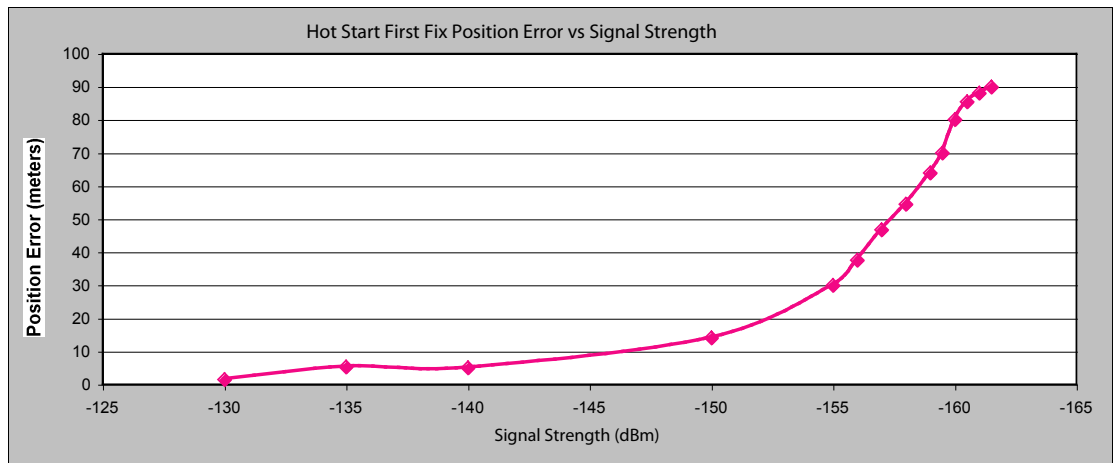
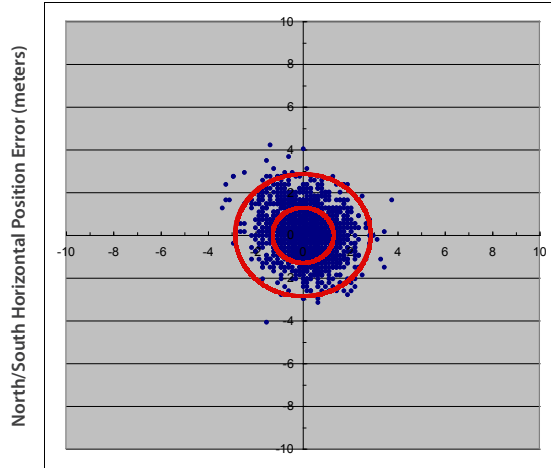

Figure 6: Hot Start First Fix Position Error<sup>1</sup>

<sup>1</sup> Using external LNA (i.e. active antenna)

### First Fix Outdoor<sup>1</sup> Position Accuracy

50 CEP: 1.29 meters    95 CEP: 2.86 meters  
 Number of First Fixes: 2000



East/West Horizontal Position Error (meters)

<sup>1</sup> Simulator test with all signals at -130 dBm with external LNA

### First Fix Indoor<sup>1</sup> Position Accuracy

50 CEP: 12.45 meters    95 CEP: 29.43 meters  
 Number of First Fixes: 1135

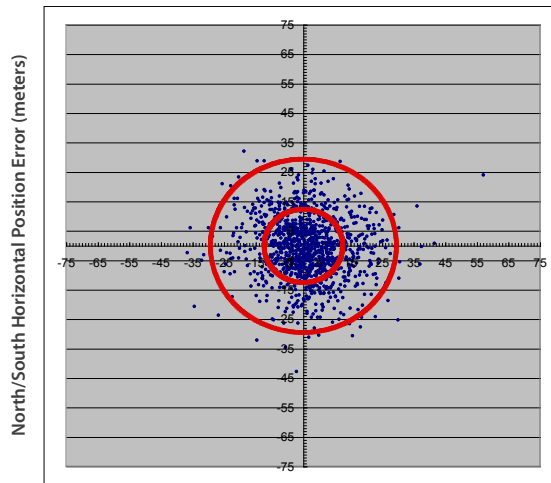

East/West Horizontal Position Error (meters)

<sup>1</sup> Simulator test with all signals at -150 dBm with external LNA

Figure 7: First Fix Outdoor and Indoor Position Accuracy



## 4 Electrical Characteristics

### 4.1 Absolute Maximum Ratings

Stress above the limits listed in the following table may cause permanent failure. Exposure to absolute ratings for extended time periods may affect device reliability. The limiting values are in accordance with the Absolute Maximum Rating System (IEC 134). All voltages are referenced to ground.

Symbol	Parameter	Conditions	Min	Max	Unit
	VCC, VBK Supply voltage	-	- 0.4	3.65	V
	VANT Supply voltage	-	- 0.4	6 (tbc)	V
	VCOR voltage	-	- 0.4	1.8 (tbc)	V
	Other terminal voltages	-	- 0.4	3.65	V
V <sub>ES</sub>	Electrostatic handling <sup>(1) &amp; (2)</sup>		-	2000	V

<sup>(1)</sup> Tested according to MIL883C Method 3015.6 (Standardized Human Body Model: 100 pF, 1500 Ω, 3 pulses, protection related to substrate).

<sup>(2)</sup> Static and dynamic latch-up values are valid at room temperature.

Table 2: Absolute Maximum Ratings

### 4.2 Electrical Specifications

Temperature TA = 20°C, VCC = 3.0 V, VBK = 2.0 V, unless otherwise stated

Symbol	Parameter	Conditions	Min	Typ	Max	Unit
Supply Voltages						
Vcc	Supply Voltage to pin VCC		3.0	3.3	3.6	V
Vbk	Back-up supply to pin VBK		1.8		3.6	V
Vant	Supply pin VANT	With the recommended GPS antenna, VANT should be left not connected (n.c.)				
Vcore	Core supply voltage, pin VCOR	To be provided only when internal regulator is bypassed	0.96	1	1.1	V
Power-on Reset						
Vrth_por	Power On Reset Threshold voltage (rising)	VCC rising	2.75		2.8	V



# OPUS III ezRide-22 Datasheet

## 32 Channel GPS / AGPS and 2 Channel SBAS Receiver

Part# eMD3622F  
 October 25, 2007  
 eDS-3622F0001-00B

Symbol	Parameter	Conditions	Min	Typ	Max	Unit
Vfth_por	Power On Reset Threshold voltage (falling)	VCC falling	2.6		2.65	V
<b>Digital Inputs/Outputs</b>						
Vil	Input low voltage level				0.8	V
Vih	Input high voltage level		2			V
Vhyst	Schmitt trigger hysteresis on digital inputs		300		800	mV
Vol	Output low voltage level	I <sub>ol</sub>   = 2 mA			0.3	V
Voh	Output high voltage level	I <sub>oh</sub>   = 2 mA	2.7			V
Rpu	Eq. Input pull-up resistance on digital inputs	V <sub>i</sub> = 0V	29		67	kΩ
Rpd	Eq. Input pull-down resistance on digital inputs	V <sub>i</sub> = 3V	29		103	kΩ
<b>Current Consumptions</b>						
I <sub>vbk1</sub>	VBK	Mode 1 - RTC mode Note : in Mode 2, 3, and 4 only leakage flow from VBK		12		μA
I <sub>vcc4a</sub>	VCC Acquisition	Mode 4 – GPS mode Satellite acquisition phase, VCOR_SEL n.c.		62		mA
I <sub>vcc4i</sub>	VCC Tracking Outdoor	Mode 4 – GPS mode Tracking satellite outdoor @ -135 dBm signal level, VCOR_SEL n.c.		40		mA
I <sub>vcc4o</sub>	VCC Tracking Indoor (-155 dBm signal level)	Mode 4 – GPS mode tracking satellite indoor SV's @ -155 dBm signal level, VCOR_SEL n.c.		58		mA
I <sub>vcc2</sub>	VCC Stand-by	Mode 2 – Stand By mode VCOR_SEL n.c.		12		mA
<b>Power Consumption</b>						
P <sub>vbk1</sub>	VBK	Mode 1 - RTC mode Note °: in Mode 2, 3, and 4 only leakage flow from VBK		24		μW
P <sub>vcc4a</sub>	VCC Acquisition	Mode 4 – GPS mode Satellite acquisition phase, VCOR_SEL n.c.		186		mW

Symbol	Parameter	Conditions	Min	Typ	Max	Unit
Pvcc4i	VCC Tracking Outdoor	Mode 4 – GPS mode Tracking satellite outdoor @ -135 dBm signal level, VCOR_SEL n.c.		120		mW
Pvcc4o	VCC Tracking Indoor (155 dBm signal level)	Mode 4 – GPS mode Tracking satellite indoor SV's @ -155 dBm signal level, VCOR_SEL n.c.		174		mW

## 4.3 Device Terminal Descriptions

### 4.3.1 GPS Antenna Input - ANT

ANT input is connected to the external GPS antenna. It is matched to 50 ohm

### 4.3.2 Serial Port#1 Interface Input/Output – TXD, RXD

TXD and RXD are the output and input of the primary bidirectional UART port used for NMEA and eSIP communications. RXD is configured with an internal pull-up.

### 4.3.3 Pulse Per Second Signal Output - PPS

The PPS hardware pin provides a way to synchronize an external device with the accurate GPS time. It provides a Pulse Per Second signal, where the rising edge of the PPS output is synchronous with the GPS time second.

There are two fundamental configurations of the PPS output: fine PPS and coarse PPS. In coarse PPS mode, PPS output is synchronized with an internal milliseconds counter but is not tied to the GPS time. Therefore, eMD3622F may output it even when no position fix is available. Fine PPS mode is steered GPS-time synchronous mode and is only available once a position fix with accurate GPS time has been achieved.

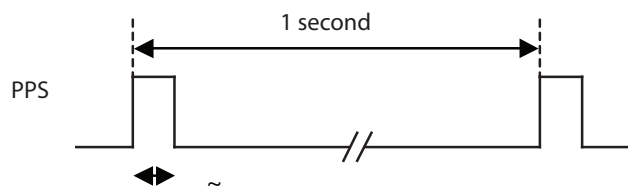

Figure 8: PPS Timing

### 4.3.4 GPS Receiver On, Off, and Standby Selection – ON/OFF/SBY

ON/OFF/SBY is an active high pin, configured as an input pin. After power up of the device, it is used to switch between various mode of operation (see chapter 6.2, in particular 6.2.2.1).



### 4.3.5 External Reset – NRST

NRST is an active low-level input, configured with an internal pull-up. It is asserted asynchronously, and a safe reset negative pulse duration is 31 microseconds. Exit from reset is synchronized internally to the MCU clock and happens up to 0.25 millisecond after the rising edge of NRST.

### 4.3.6 JTAG Interface I/O's – TMS, TDO, TDI, TCK, TRSTn

These pins connect to the standard JTAG test interface (3.3 V interface).

### 4.3.7 Power Supplies

#### 4.3.7.1 VCC

eMD3622F operates from a single 3.0 to 3.6 V supply, using embedded regulators.

#### 4.3.7.2 VBK

An embedded Real Time Counter as well as GPS data, incl. satellite model data are located in a battery backed up section of eMD3622F. VBK must be turned On whenever VCC is turned off for proper operation, otherwise these battery backed up data will be lost.

VBK must be turned On before or at the same time VCC is turned On. Otherwise, the power management circuitry won't start and the module won't operate. For applications which do not need to back up these data when VCC is turned Off, VBK should be connected to VCC.

#### 4.3.7.3 VANT

VANT should be left not connected (n.c.).

#### 4.3.7.4 VCOR and VCOR\_EN, VCOR\_SEL

In standard mode of operation all the necessary voltage supplies are derived on-board from VCC. However, the internal regulator which supplies the GPS receiver core (ePV3600) can be bypassed by connecting VCOR\_SEL to VCC. In this case, eMD3622F needs an external 1.0 V voltage supply VCOR whenever VCOR\_EN is High.

For applications where this bypass feature is not used, VCOR and VCOR\_EN should remain not connected (n.c.). VCOR\_SEL should be left un-connected or connected to ground.

### 4.3.8 Frequency Differential Inputs – VCOCLK, VCOTRIG

The Frequency Differential feature allows the host application to provide an external frequency reference, typically an XO, to accurately estimate and reduce the GPS receiver frequency window search. eMD3622F then compares the external reference frequency to the 27.456 MHz master clock frequency and estimate the frequency drift. A more accurate frequency enables a reduced frequency search window, which means reduced time to first fix.

For applications where this feature is not used, VCOCLK and VCOTRIG may remain not connected (n.c.) or connected to ground

### 4.3.9 Time Differential Input - EPPS

The Time Differential feature allows the host application to provide a precise estimate of the current time (within a few microseconds) with the External Pulse Per Second (EPPS) signal. eMD3622F then measures the time difference between its internal reference (millisecond update event) and the EPPS pulse to compute the appropriate GPS time estimate. The Time Differential feature allows the GPS receiver to quickly acquire very weak signals and thus to fast time to first fix even under these critical conditions.

For applications where this feature is not used, EPPS may remain not connected (internal pull-down) or connected to ground.

### 4.3.10 Frequency Generator Output – FG2CLK

FG2CLK is the output of an embedded programmable frequency generator, between 1 Hz to 27.456 MHz. This feature is not supported in the current revision of eMD3622F

### 4.3.11 General Purpose I/O's – GPIO[5:4]

GPIO[5:4] are programmable general purpose I/O's. This feature is not supported in the current revision of eMD3622F

### 4.3.12 Serial Port#2 Interface Input/Output – TX2/SDO/SDA, RX2/SDI, SCLK

TX2/SDO/SDA and RX2/SDI are the output and input of a secondary bidirectional serial port which can be configured as a UART, a SPI, or a I2C port (mutually exclusive). SCLK is the serial clock when SPI or I2C modes are selected. For SPI bus operation, the Slave Select line should be emulated with one of the GPIO. Alternatively, the SS pin of the remote device can be hard-wired.

This feature is not supported in the current revision of eMD3622F

### 4.3.13 Test Mode Selection Input – PTMODE

PTMODE is reserved for internal test purpose. In standard operating conditions it should be connected to VCC or remain not connected (n.c.).

## 5 Mechanical Specifications, Pinning

### 5.1 Package Outline

22.0 mm (L) x 22.0 mm (W) x 3.0 mm (H) SMD Module

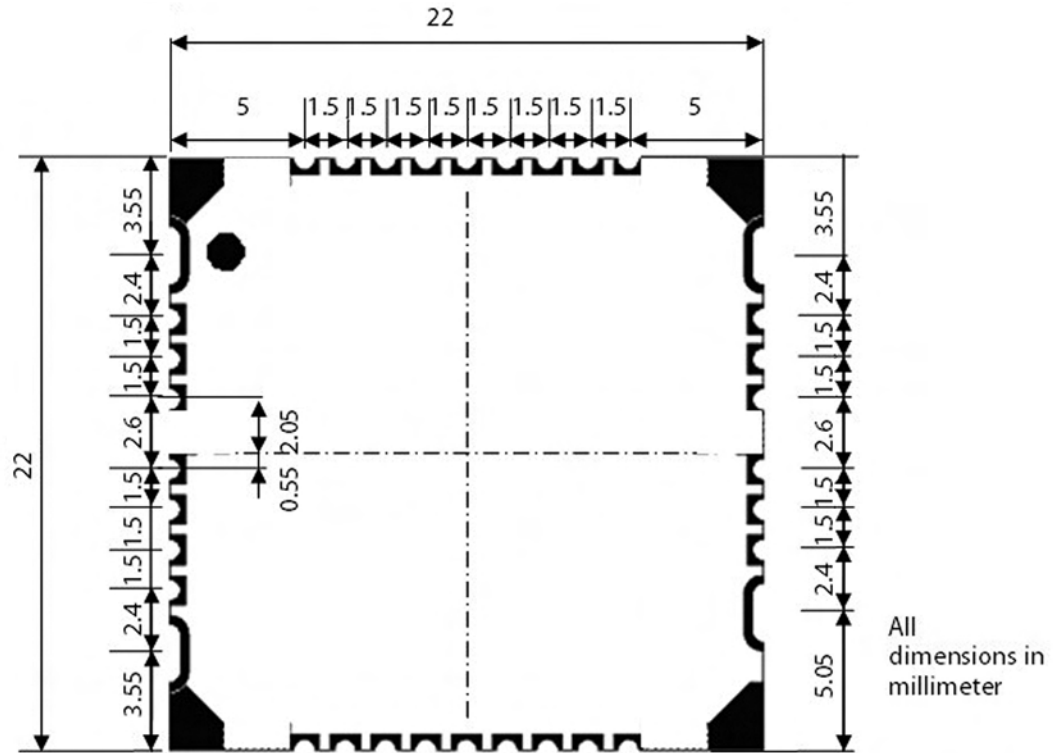

Figure 9: Pin Location (Top View)

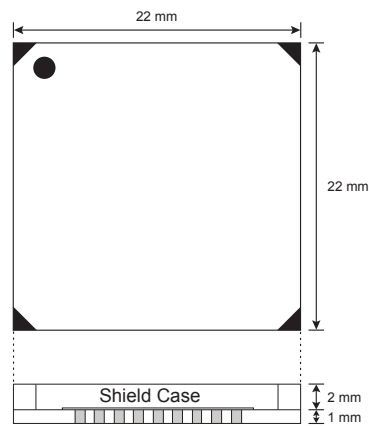

Figure 10: Shield Case Dimensions



# OPUS III ezRide-22 Datasheet

## 32 Channel GPS / AGPS and 2 Channel SBAS Receiver

Part# eMD3622F  
 October 25, 2007  
 eDS-3622F0001-00B

## 5.2 Pin Description

### 5.2.1 Pin List

This table shows the pin names, their type (DI-digital input, DO-digital output, AI-analog input, AO-analog output, OD-open drain, P-power), whenever they have pull-up/pull-down when in input mode (PU-pull-up, PD-pull-down), the I/O voltage, and the description.

#	Pin Name	Type	PU/PD	Volt	Description
1	VANT				Should be left not connected (n.c.)
2	GND				Ground
3	ON/OFF/SBY	DI		VCC	GPS On, - Off, or – Standby control line, active low
4	GND				Ground
5	GND				Ground
6	GND				Ground
7	ANT	AI			GPS antenna input
8	VCOTRIG	DI	PD	VCC	VCO clock Enable
9	FG2CLK	DO		VCC	Frequency generator output
10	VCOCLK	DI	PD	VCC	VCO clock input, reference for frequency aiding
11	VBK	P			Back up supply for RTC and BBRAM
12	VCOR_EN	DO		VCC	Enable external 1 V supply (optional, only when on-chip regulator is bypassed)
13	NRST	DI	PU	VCC	System reset, active Low
14	RXD	DI	PU	VCC	Serial port#1 (UART) receive line
15	TXD	DO		VCC	Serial port#1 (UART) transmit line
16	RX2/SDI	DI		VCC	Serial port#2 (UART or SPI) receive line
17	TRSTn	DI	PD	VCC	JTAG test interface reset, active low
18	GPIO[5]	DI/DO	PD (DI)	VCC	General purpose I/O
19	TX2/SDO/SDA	DO		VCC	Serial port#2 (UART or SPI) transmit line, or data line (I2C)
20	VCOR_SEL				Should be left not connected (n.c.)
21	SCLK	DO		VCC	SPI or I2C clock
22	VCOR	P			External 1 V supply for core (optional, only when on-chip regulator is bypassed)
23	VCC	P			Main power supply

#	Pin Name	Type	PU/PD	Volt	Description
24	GPIO[4]	DI/DO	PD (DI)	VCC	General purpose I/O
25	TMS	DI	PU	VCC	JTAG interface, test mode select
26	TCK	DI		VCC	JTAG interface, test clock
27	EPPS	DI	PU	VCC	External pulse per second, aiding time reference
28	TDO	DO		VCC	JTAG interface, test data output
29	PTMODE	DI		VCC	Internal test mode select line, active low
31	TDI	DI	PU	VCC	JTAG interface, test data input
31	PPS	DO		VCC	Pulse per second

Table 3: Pin List

### 5.2.2 Pin Assignment

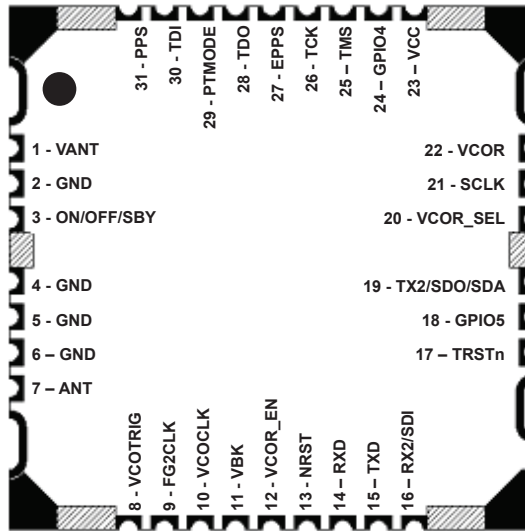

Figure 11: Pin Assignment (Top View)

### 5.3 Marking Description

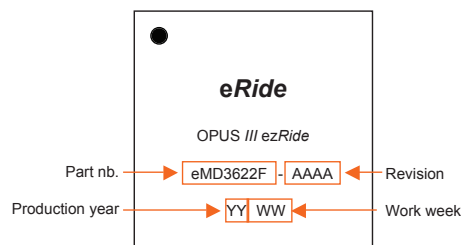

Figure 12: Marking

## 5.4 Recommended Layout

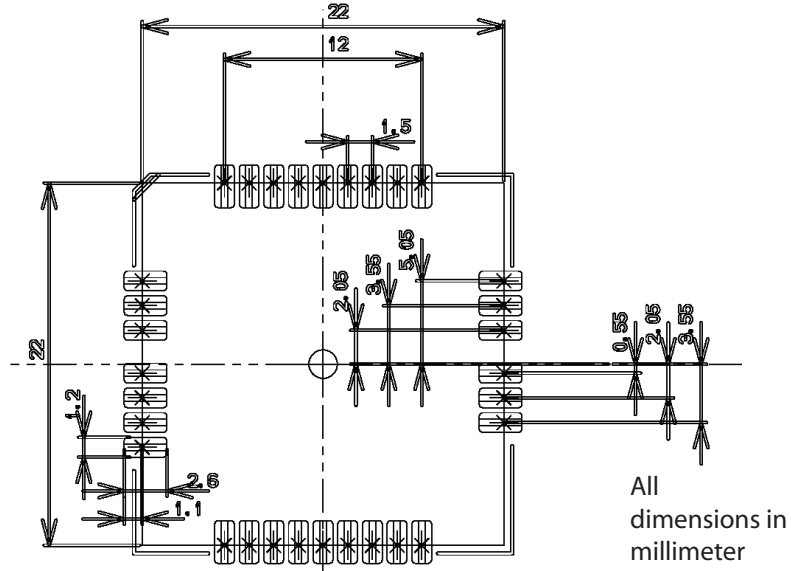

Figure 13: Recommended Footprint Pad Size

## 6 Software Specifications

### 6.1 NMEA and ESIP - eRide Serial Communications Interface Protocol

eMD3622F provides and receives data over a serial port to and from another device. In a typical application eMD3622F is connected to a handset, notebook, palmtop, laptop, PC, smartphone, car navigation system, although this protocol would be applicable to other implementations that can interface with the serial link.

eMD3622F uses a UART port interface model on the UART1, which is both RXD1 and TXD1 I/O lines. The serial interface can operate at different baud rates. Standard mode (factory settings, only NMEA data) operates at 9600 baud, 8 data bits, no parity and one stop bit. There is also a high-speed diagnostics output (115.2 kbaud 8 data bits, no parity and one stop bit) for use in trouble-shooting systems.

#### 6.1.1 NMEA Standard Output Messages

eMD3622F supports NMEA-0183 v3.0. It provides the standard output messages GGA - Global positioning system fixed data, GLL - Geographic position latitude/longitude, GSA - GNSS DOP and active satellites, GSV - GNSS satellites in view, RMC - Recommended minimum specific GNSS data, and ZDA - Time & Date. It also supports the GPQ input message.

See the eRide Serial Interface Protocol (eSIP) User's Manual eTM-350000001 for detailed information.

### 6.1.2 eSIP Proprietary Input and Output Messages

eMD3622F supports the eRide Serial Interface Protocol (eSIP), which is a set of vendor specific ASCII sentences compliant with the NMEA 0183 Standard. Unlike NMEA standard sentences, the eSIP sentences start with the "\$PERD" string. Two types of input sentences are defined: query and set. Query sentences request certain information from the receiver. Set sentences allow configuring the receiver with certain configuration parameters or forcing the receiver to perform a specific action. For a query sentence, the receiver sends a response sentence which contains the requested data. There is no response or acknowledge to a set sentence.

See the eRide Serial Interface Protocol (eSIP) User's Manual eTM-350000001 for detailed information.

## 6.2 Principles of Operation

This chapter describes the principles of operation and features of eMD3622F.

### 6.2.1 Power Modes

In addition to the power off state – where both VBK and VCC turned Off -, the device has four main operating power modes, as summarized in the table below.

Mode	Description	VBK	VDDM
0 - Off	No backup battery, no other supply All data lost	OFF	OFF
1 - RTC	Backup battery present, main power supply powered off/disconnected - RTC counter & timer running, backup RAM content valid - eMD3622F can't be woken up when in this mode (need external device/action to switch VCC on)	ON	OFF
2 - Stand - By	GPS engine and MCU are turned Off - RTC counter & timer running, backup RAM content valid - RTC OR ON/OFF/SBY OR RXD line OR NRST can wake up the system	ON (or OFF <sup>1</sup> )	ON
3 - MCU	GPS engine is turned Off. MCU is up and running - GPS engine can be turned On by the ON/OFF/SBY line or upon receiving proper commands on UART1	ON (or OFF <sup>1</sup> )	ON
4 - GPS	The entire device is powered up. GPS engine can do position fixes. - GPS engine can be turned Off by the ON/OFF/SBY line or upon receiving proper commands on UART1	ON (or OFF <sup>1</sup> )	ON

**Note 1:** Transitions from Modes 0 or 1 to Mode 3 require a VBK supply. Once in Mode 2, 3, or 4, VBK can be left not connected

Table 4: eMD3622F Power Modes

The possible transitions between these different power modes are summarized in the Figure 14 below.

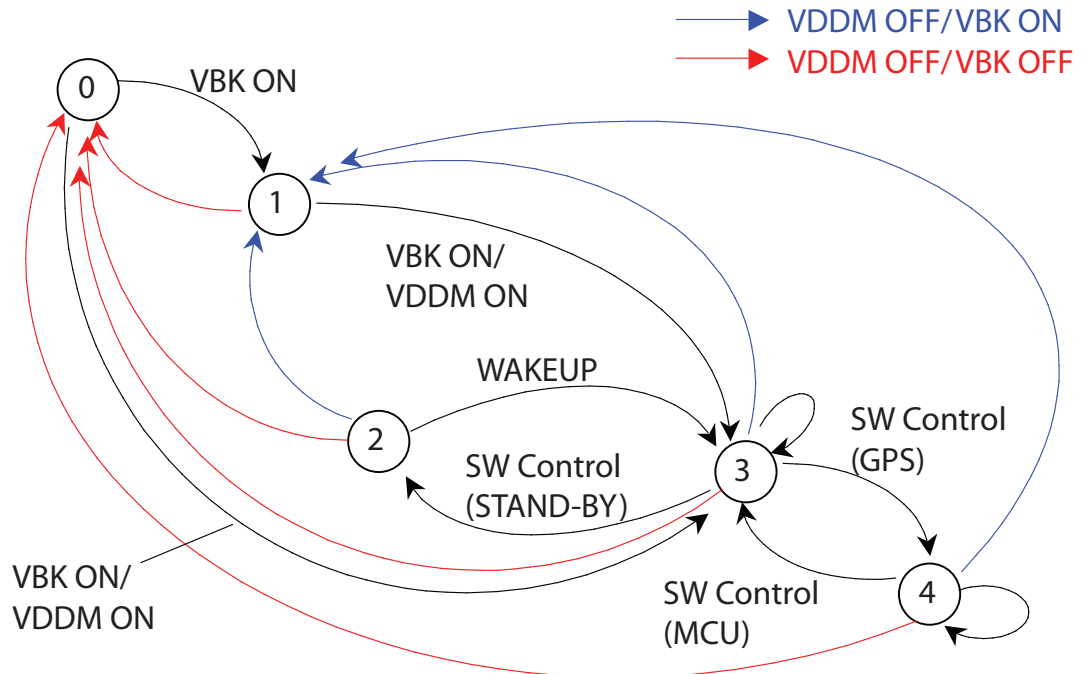

Figure 14: Power Modes Transition Diagram

The possible transitions when VCC is turned OFF while VBK is still ON are shown with the blue arrows. The possible transitions when both VCC and VBK are turned OFF simultaneously are shown with the red arrows. The transitions between Mode 3 and Mode 4 are under software control. Similarly, the transition from Mode 3 to Mode 2 is under software control. Finally, the transition between Mode 2 to Mode 3 depends on cold wake-up conditions, as described in 6.2.1.7.

### 6.2.1.1 Mode 0 – OFF & Mode 1 – RTC

In Mode 0, OFF mode, there is no power supply to the module, so all data, including data in the backup RAM and RTC counter, are lost.

In Mode 1, RTC mode, there is only the backup supply on VBK available to maintain the embedded RTC counter & timer running, and to maintain data in the backup RAM for GPS data.

### 6.2.1.2 Mode 2 – Stand-By

In Mode 2, Stand-by mode, both main and backup supplies are available. However, the embedded GPS engine and MCU are turned Off. While in this mode, the system expects a cold wake-up condition to occur.

Stand-by mode is currently not supported by the *ezRide-22* software. Please contact your *eRide* sales representative for availability of software upgrade.

### 6.2.1.3 Mode 3 - MCU

In Mode 3, MCU mode, both main and backup supplies are available. The GPS engine is turned Off. The system waits for commands from the eSIP interface or activity on the ON/OFF/SBY input.

### 6.2.1.4 Mode 4 - GPS

In Mode 4, GPS mode, the entire module is powered up. The GPS receiver is in acquisition mode or tracking mode. While in Mode 4, the device sends standard NMEA and eSIP proprietary sentences through the UART1 port. It also accepts eSIP set and request commands and responds to activity on the ON/OFF/SBY input.

### 6.2.1.5 Power Up

Power Up is defined here as the transition from Mode 0 or Mode 1 to Mode 3, then to Mode 4 when VCC supplied to the system. In Mode 0, the content of all registers is lost, including content of the RTC registers. While in Mode 1, the content of the RTC registers is maintained thanks to the VBK supply.

The transition from Mode 0 to Mode 1 is purely under hardware control, that is when the module is powered-up and the embedded power-on reset releases its reset signal.

Upon Power-up, the MCU boots up. Upon completion of this boot up sequence, when in Mode 3 - MCU, the system automatically switch to Mode 4 – GPS.

### 6.2.1.6 Power Down

Power Down is defined here as the asynchronous event that switches off the main supply VCC. Whenever in Mode 2, 3, or 4, the system will transition to either Mode 0 or Mode 1, depending on VBK status.

### 6.2.1.7 Cold Wake-Up, Cold Wake-Up Sources

The transition form Mode 2 to Mode 3, then Mode 4, depends on an external wake-up source, that is the reception of a character on RXD (falling edge) in case the ON/OFF/SBY input is pulled high, or in case of a hardware reset NRST. This is defined as the Cold Wake-up conditions. Upon cold wake-up, the system will switch to Mode 3 (MCU), then automatically to Mode 4 (GPS).

### 6.2.1.8 Shut Down GPS

The Shut Down GPS sequence is the transition from Mode 4 to Mode 3. That transition can happen upon receiving a specific command through the NMEA port or when ON/OFF/SBY is activated as described under 6.2.2.1.

### 6.2.1.9 Start Up GPS

The Start Up GPS sequence is the transition from Mode 3 to Mode 4 (when not in Power Up sequence!). That transition can happen upon receiving a specific command through the NMEA port or when ON/OFF/SBY] is activated as described under 6.2.2.1.

### 6.2.1.10 Stand By

The Stand By sequence is the transition from Mode 3 to Mode 2. That transition can happen upon receiving a specific command through the NMEA port or when ON/OFF/SBY is activated as described under 6.2.2.1.

## 6.2.2 Data Interface

The embedded application software in ROM directly interfaces with the pins that are part of the Peripherals Subsystem. The data interface features are:

### 6.2.2.1 ON/OFF/SBY

While VCC is turned On, ON/OFF/SBY controls whether the GPS engine is turned ON (Mode 4) or OFF (MCU - Mode 3), or if the device should switch to the Stand-by Mode 2.

If ON/OFF/SBY is set "High" for less than 1 second while in Mode 3, then the device switches to Mode 4 – turn the GPS engine On.

If ON/OFF/SBY is set "High" for less than 1 second while in Mode 4, then the device switches to Mode 3 – turn the GPS engine Off

If ON/OFF/SBY is set "High" for more than 3 seconds while in Mode 3 or Mode 4, then the device switches to Mode 2 – turn the GPS engine Off and go to Stand-by.

ON/OFF/SBY is enabled as a wake-up source. So, if is set "High" while in Mode 2, it will wake-up the system, which will go to Mode 3, then automatically to Mode 4.

### 6.2.2.2 RXD, TXD - Serial Receive and Transmit Data of UART1

The default settings for UART1 is 9600 Bd, 8bit data, 1 stop bit, no parity. This setting can be modified with a specific eSIP command. RXD is enabled as a cold wake-up source, which means if this pin goes "Low" while in Mode 2, it will wake-up the system, which will go to Mode 3, then automatically to Mode 4. It is assumed the first data bytes sent to wake-up eMD3622F is lost and won't be processed.

### 6.2.2.3 Other Data Interface

TMODE is not used in normal operation.

PPS behaves as described in 4.3.3.

The other data interfaces are not used in the current version.

### 6.2.3 GPS Data Back-Up

The High Accuracy Satellite Model (HASM), the Low Accuracy Satellite Model (LASM), the UTC time offset, and the approximate position, as well as other data that allow the GPS receiver to rapidly acquire satellites upon start up are stored in the battery backed up RAM (BDRAM). The BDRAM content is updated every 30 seconds.

## 7 Application Information

### 7.1 Application Circuit, Low Cost GPS/A-GPS Receiver

The diagrams below outline the minimum suggested configuration for a full GPS / A-GPS receiver based on eMD3622F which interface to the application only through the UART NMEA/eSIP port, and with a rechargeable ML back-up battery.

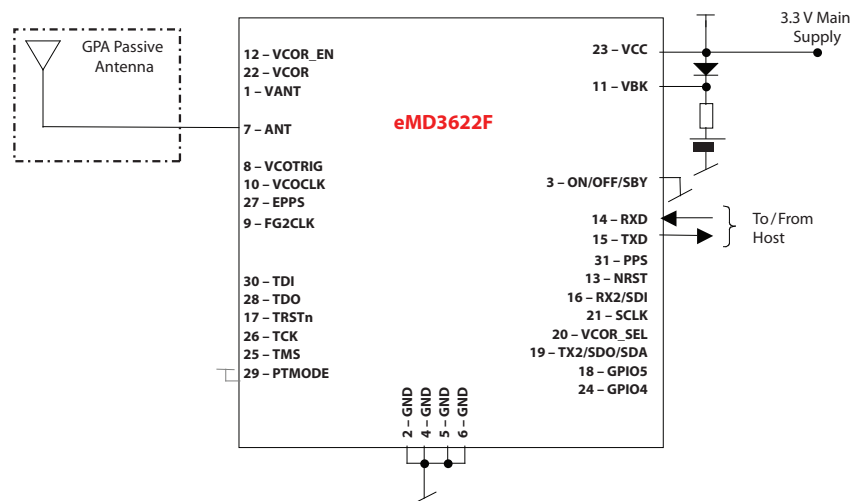

Figure 15: Low Cost GPS/A-GPS Receiver

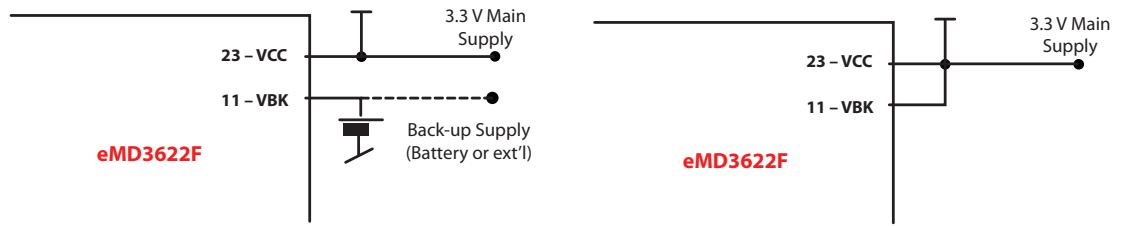

Figure 16: Alternative Back-Up Supply Schemes

## 7.2 Recommended GPS Antenna

For proper operation, eMD3622F should be operated with a GPS antenna having the following characteristics

Symbol	Parameter	Conditions	Min	Typ	Max	Unit
	Center frequency	2.046 MHz bandwidth		1575.42 2		MHz
	Absolute Gain	At Zenith		5		dBi
	Output VSWR				1.5	
	Impedance			50		ohm

Table 5: Recommended Antenna Specifications

## 8 Environmental Specifications

Symbol	Parameter	Conditions	Min	Max	Unit
T <sub>A</sub>	Operating Ambient Temperature Range	(1)	-40	+85	°C
T <sub>STG</sub>	Storage Temperature Range	(to be updated)	-40	+85	°C
	Humidity level	T <sub>a</sub> = 60°C No condensation	-	95	% R. H.

**Note:** (1) with degraded GPS performances at low temperatures

Table 6: Environmental Specifications



## **9 Packing and Product Handling**

### **9.1 Carrier Tape and Reel Dimensions**

To be updated.

### **9.2 Component Orientation for Tape and Reel**

To be updated.

### **9.3 Packaging and Delivery**

To be updated.

## 9.4 Reflow Profile

eMD3622F is a static-sensitive electronic device. Do not operate or store near strong electrostatic fields. Follow guidelines as per EIA/JESD22-A115-A.

	Symbol	Value
Preheat min. temperature	$T_{smin}$	150°C
Preheat max. temperature	$T_{smax}$	200°C
Preheat duration	$t_s$	60 to 180 seconds
Melting point	$T_L$	217°C
Time above melting point $T_L$	$t_L$	60 to 150 seconds
Peak Temperature	$T_p$	240°C - 250°C
Time within 5°C to the peak temperature	$t_p$	10 to 30 seconds
Ramp-up Rate ( $T_{smax}$ to $T_p$ )		3°C/second max
Ramp-down Rate		6°C/second max

**Note 1:** According to JED EC J-STD-020C eMD3622 is qualified with 250°C max. peak temperature, temperature being measure on top of the shielding.

**Note 2:** Time within 5 °C of actual peak temperature ( $t_p$ ) specified for the reflow profiles is a “supplier” minimum and “user” maximum.

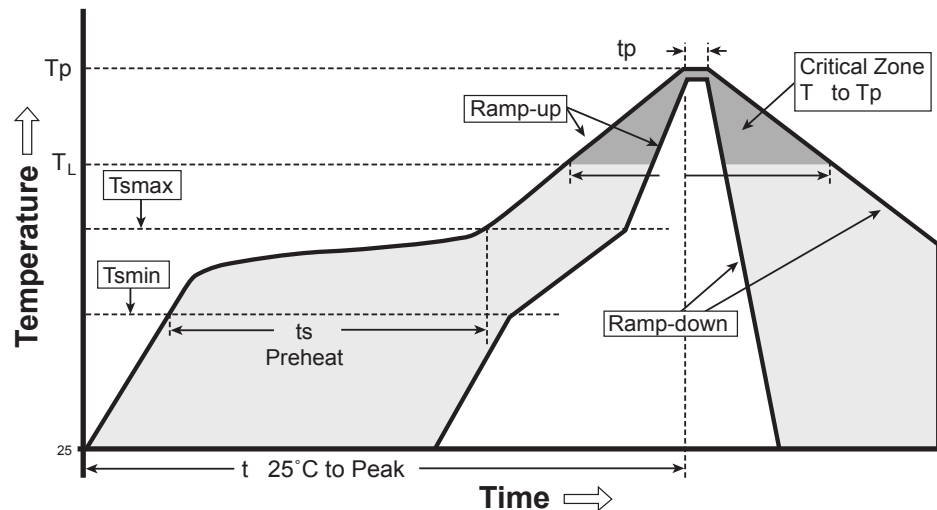

Table 7: Pb-free Process - Package Peak Reflow Temperatures

Extracted from IPC/JEDEC J-STD-020C, reference full specification for more details.



# OPUS III ezRide-22 Datasheet

## 32 Channel GPS / AGPS and 2 Channel SBAS Receiver

Part# eMD3622F  
October 25, 2007  
eDS-3622F0001-00B

### 9.5 ESD Sensitivity

Follow guidelines as per EIA/JESD22-A115-A.

### 9.6 RoHS Compliance

eMD3622 products are compliant with the European Union Directive 2002/95/EC Restriction on the Use of Hazardous Substances (RoHS). All designated products have Pb-free terminals.



# OPUS III ezRide-22 Datasheet

## 32 Channel GPS / AGPS and 2 Channel SBAS Receiver

Part# eMD3622F  
 October 25, 2007  
 eDS-3622F0001-00B

### 10 Ordering Information

Part Number	Package	Supplying Form
eMD3622F	22.0 x 22.0 x 3.0 mm 31 pins fully assembled module	• x mm wide -> to be determined • 0K/reel -> to be determined

#### 10.1 Worldwide Sales Offices

**USA**  
 eRide Headquarters  
 Tel: +1 (415) 848-7800  
 One Letterman Drive  
 Building C, Suite 310  
 San Francisco, CA  
 94129-1492, USA  
 Contact@eRide.com

**Japan**  
 eRide Asia Pacific limited,  
 Tel: +81 (3) 5730-7880  
 Fax: +81 (3) 5730-7881  
 Sumitomo Mita Bldg. 1F  
 Shiba 5-37-8, Minato-ku  
 Tokyo, 108-0014, Japan  
 InfoJapan@eRide.com

**Europe**  
 eRide Europe GmbH  
 Tel: +49 (89) 92861570  
 Fax: +49 (89) 928615722  
 Dornacher Strasse 3e  
 85622 Feldkirchen bei München, Germany  
 InfoEurope@eRide.com

**Korea**  
 eRide Korea Co, Ltd.  
 Tel: +82 (2) 577-9151  
 Fax: +82 (2) 577-9130  
 #601, Bethel B/D., 324-1  
 Yangjae-Dong, Seocho-ku  
 Seoul, 137-897, Korea  
 InfoKorea@eRide.com

[www.eRide.com](http://www.eRide.com)

The contents of this document are subject to change without notice. Customers are advised to consult with eRide sales representatives before ordering.

The information and circuit diagrams in this document presented as examples of semiconductor device applications, and are not intended to be incorporated in devices for actual use. Also, eRide is unable to assume responsibility for infringement of any patent rights or other rights of third parties arising from the use of this information or circuit diagrams. No license is granted by implication or otherwise under any patent or patent rights of eRide Inc.

CAUTION: Customers considering the use of our products in special applications where failure or abnormal operation may directly affect human lives or cause physical injury or property damage, or where extremely high levels of reliability are demanded (such as aerospace systems, atomic energy controls, sea floor repeaters, vehicle operating controls, medical devices for life support, etc..) are requested to consult with eRide sales representatives before such use. The company will not be responsible for damages arising from such use without prior approval.

Any semiconductor devices have inherently a certain rate of failure. You must protect against injury, damage or loss from such failures by incorporating safety design measures into your facility and equipment such as redundancy, fire protection, and prevention of over-current levels and other abnormal operating conditions.

If any products described in this document represent goods or technologies subject to certain restrictions on export under the Foreign Exchange and Foreign Trade Control Law of Japan, the prior authorization by Japanese government should be required for export of those products from Japan.

ARM7TDMI is a registered trademark of ARM Ltd.