

Wide Band Multi-Channel RF Transceiver Module

Product Description

The RC1040, RC1080 and RC1090 RF Transceiver Modules are compact surface-mounted modules for wide band FSK operation with embedded protocol. The modules are completely shielded and pre-certified for operation under the European and US radio regulations for license-free use. When used with quarter-wave antennas a line-of-sight range of 500 meter can be achieved at 433 MHz.

Applications

- OEM equipment
- Radio modems
- Point-of-sales terminals
- Bar code scanners
- Telemetry stations
- Fleet management



Features

- Smallest in the world (12.7 x 25.4 x 3.5 mm)
- Very low current consumption, 3nA OFF mode
- Embedded RC232™ protocol
- Addressing
- Error check
- 128 byte data buffer
- Simple UART interface for easy RS232/422/485 wire replacement
- Compact shielded module for SMD mounting
- No external components
- No configuration required for single-channel use
- Easy to use data interface, 3/5 V tolerant I/O
- Multi-channel operation
- Wide supply voltage range, 2.8 – 5.5 V
- Conforms with EU R&TTE directive (EN 300 220, EN 301 489, EN 60950)
- Conforms with FCC CFR 47 part 15

Quick Reference Data

| Parameter | RC1040 | RC1080 | RC1090 | Unit |
|----------------------------|---------------|-----------|-----------|--------|
| Frequency band | 433.05-434.79 | 868 - 870 | 902 - 928 | MHz |
| Number of channels | 5 | 8 | 9 | |
| Data rate | 19.2 | | | kbit/s |
| Max output power | 9 | 5 | -1* | dBm |
| Sensitivity | -95 | -95 | -95 | dBm |
| Supply voltage | 2.8 – 5.5 | | | Volt |
| Current consumption, RX | 10.5 | 13 | 13 | mA |
| Current consumption, TX | 25 | 25 | 25 | mA |
| Current consumption, SLEEP | 85 | | | uA |
| Current consumption, OFF | 0.003 | | | uA |

* Programmable. Maximum allowed radiated power under FCC CFR 47, part 15 is -1 dBm ERP.

PRELIMINARY INFORMATION. Specifications and information herein are subject to change without notice.

Typical Application Circuit

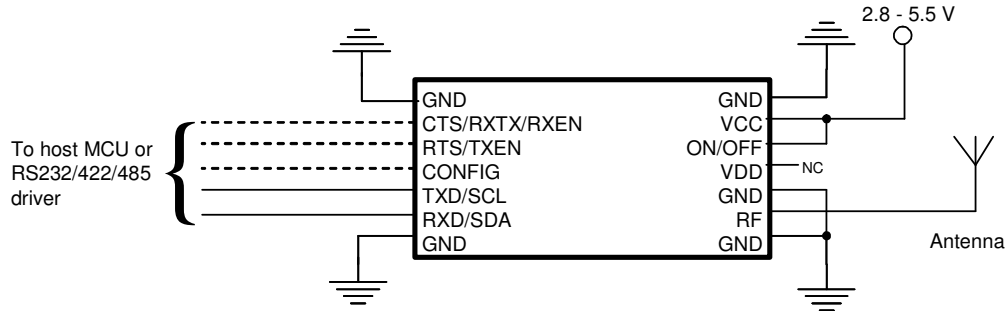

Quick Product Introduction

How do I transmit data?

Send your data to the RXD pin on the module. Use the UART format with settings (19200, 8, 1, N, no flow control). Up to 128 bytes are buffered in the module. The module will transmit the data when

- the max packet length is reached
- the unique end character is sent
- the modem timeout limit is reached

The packet length, end character and timeout limit are configurable in-circuit.

How do I receive data?

Any received data packet with correct address and check sum will be sent on the TXD pin using the same UART format as for transmit.

What about the antenna?

In most cases a simple quarter wavelength wire or a PCB track will do. Connect a piece of wire to the RF pin with length corresponding to the quarter of a wavelength. For space limited products, contact Radiocrafts and we will recommend the best antenna solution for your application.

How do I change the RF channel or any other parameter?

To change configurable parameters, assert the CONFIG pin, and send the command string using the same serial interface as for transmitting data. Parameters can be changed permanently and stored in non-volatile memory in the module.

Pin Assignment

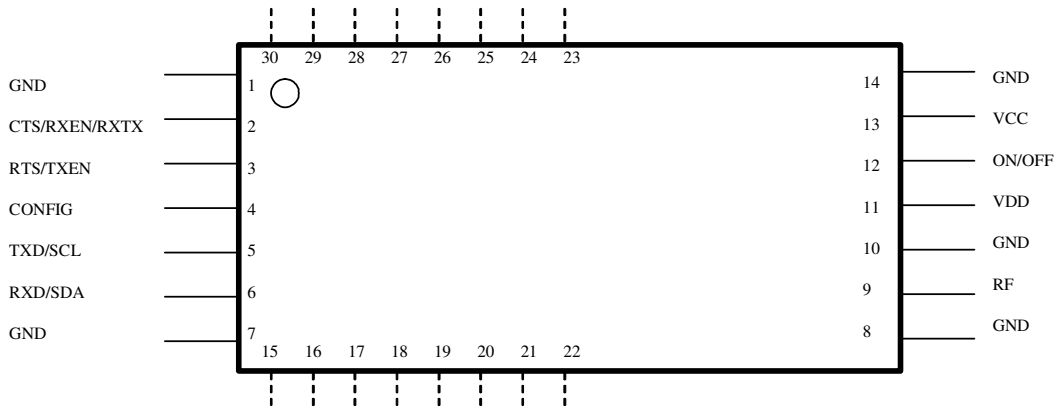

Pin Description

| Pin no | Pin name | Description |
|--------|---------------|--|
| 1 | GND | System ground |
| 2 | CTS/RXTX/RXEN | UART Clear to Send, UART RXTX, Receive Mode Enable, or SLEEP mode activation. Connect to VDD if not used. Internal 100 kΩ series resistor. |
| 3 | RTS/TXEN | UART Request to Send, Transmit Mode Enable, or SLEEP mode activation. Connect to VDD if not used. Internal 100 kΩ series resistor. |
| 4 | CONFIG | Configuration Enable. Active low. Should normally be set high. Connect to VDD if not used. Internal 100 kΩ series resistor. |
| 5 | TXD/SCL | UART TX Data, or serial data clock. Internal 100 kΩ series resistor. |
| 6 | RXD/SDA | UART RX Data, or serial data I/O. Internal 100 kΩ series resistor. |
| 7 | GND | System ground |
| 8 | GND | System ground |
| 9 | RF | RF I/O connection to antenna |
| 10 | GND | System ground |
| 11 | VDD | Supply voltage output, regulated. Should normally be left open |
| 12 | ON/OFF | Module on/off (shutdown). ON when high, OFF when low. See important note under Power Management page 5. |
| 13 | VCC | Supply voltage input. Internally regulated. Maximum rise-time requirement apply, see Electrical Specification. |
| 14 | GND | System ground |
| 15-18 | RESERVED | Test pins or pins reserved for future use. <i>Do not connect!</i> |
| 19 | RSSI | Received signal strength indicator, analogue output |
| 20-21 | RESERVED | Test pins or pins reserved for future use. <i>Do not connect!</i> |
| 22 | RESET | Main reset (active low). Should normally be left open. Internal 100 kΩ pull-up resistor, no series resistor. |
| 23-30 | RESERVED | Test pins or pins reserved for future use. <i>Do not connect!</i> |

Note 1: In UART mode the TXD and RXD are used for serial data, and CTS/RXTX and RTS for flow control (optional). If flow control is not used, and RXEN and TXEN are both asserted (active low) the module is set in SLEEP mode. RXEN and TXEN should be connected to VDD if not used if not used for SLEEP mode activation. A pull-up resistor is not necessary due to an internal series resistor.

Note 2: In synchronous mode the SCL (data clock) and SDA (Data input and output) are used for serial data. The RXEN and TXEN pins are then used to select the operation mode of the device. Signals are active low.

Note 3: The CONFIG pin is used to enter configuration mode (change of default settings). Active low.

Note 4: Do not use VDD for supply to external circuits. Should only be used for RXEN and TXEN pull-up, if required.

Note 5: RXEN, TXEN, CONFIG, TXD and RXD have internal 100 kΩ series resistors.

Note 6: Other digital interfaces may be specified upon request.

Block Diagram

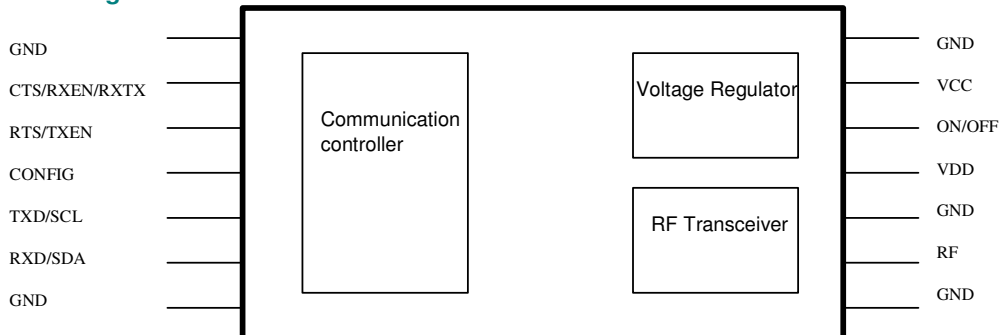

Circuit Description

The module contains a communication controller with embedded RC232™ protocol software, an RF transceiver and an internal voltage regulator.

The communication controller handles the radio packet protocol, the UART interface and controls the RF transceiver. Data to be sent by the host is received at the RXD pin and buffered in the communication controller. The data packet is then assembled with preamble, start-of-frame delimited (SOF), address information and CRC check sum before it is transmitted on RF. The preamble and SOF is always used. The address and CRC are optional.

The RF transceiver modulates the data to be transmitted on RF frequency, and demodulates data that are received.

Received data are checked for correct address and CRC by the communication controller. If the address matches the modules own address, and no CRC errors were detected, the data packet is sent to the host on the TXD line after removing the header.

The asynchronous UART interface consists of RXD and TXD. Optionally CTS, RTS/RXTX can be used for hardware handshake flow control. RTS/RXTX can be used to control the direction of an RS485 driver circuit.

The module can also be used in an un-buffered transparent mode. In this case the data interface is synchronous using SCL and SDA for data transfer to/from the host. The RXEN and TXEN are then used to set the operational mode.

When the CONFIG pin is asserted the communication controller interprets data received on the RXD pin as configuration commands. There are commands to change the radio channel, the output power, the destination address etc. Permanent changes of the configuration is also possible and are then stored in internal non-volatile memory (EEPROM).

The RF protocol and the configuration commands are described in detail in the RC232™ User Manual.

The supply voltage is connected to the VCC pin. The module contains an internal voltage regulator and can therefore operate over a wide supply voltage range. The regulated voltage is available at the VDD pin, but should not be used to supply external circuits.

The ON/OFF pin can be used to turn the module completely off, and hence reduce the power consumption to a minimum. For normal operation the ON/OFF pin must be connected to VCC. To turn the module completely off, connect the ON/OFF pin to ground (logic low level).

RC232™ Embedded Protocol

The module offers a buffered packet radio as well as an un-buffered transparent mode in the RC232™ embedded protocol.

Using the buffered packet radio mode, all data to be sent is stored in the module before they are transmitted by the RF circuitry. Likewise, when data is received they are stored in the module before they are sent to the host. This allows the communication controller to add address information and to do error check of the data. In buffered mode the UART interface is used to communicate with the host.

If the application requires a transparent data link, the module can be configured to operate in an un-buffered mode. In this mode the module adds only a preamble and start-of-frame bytes to synchronize the receiver. No addressing or checksum is provided in this case. A synchronous interface is used to transfer data to/from the host. Note however, that the configuration of the module is done using the UART even if the un-buffered mode is used for data transfer.

The embedded protocol, configuration commands and configuration memory is described in the RC232™ User Manual. This protocol is used in a wide range of RF modules available from Radiocrafts. Please refer to the latest revision available on Radiocrafts web-site.

Power Management

The module can be set in SLEEP mode or OFF mode in order to reduce the power consumption.

The low power SLEEP mode is entered by using the SLEEP command, see RC232™ User Manual, or by pulling both RXEN and TXEN low. In sleep mode the module will not receive or detect incoming data, neither from the host (UART port) nor from the RF transceiver. The module is awakened from the SLEEP mode by a positive edge on the CONFIG, RXEN or TXEN pins.

Note: If UART handshake is used, the RXEN and TXEN pins can not be used to enter SLEEP mode. In this case, use the SLEEP command.

The ultra-low power OFF mode is entered by pulling the ON/OFF pin low. The module will then shut down completely. The module is turned on by setting the ON/OFF pin high (to VCC). After the module has been in OFF mode all operational parameters are set to the values stored in configuration memory.

The VDD output should not be used to supply external circuits, other than for pull-ups for RXEN, TXEN and CONFIG.

In order to ensure that the internal Power On Reset (POR) operates correctly, the maximum rise-time specification for VCC must be met (see Electrical Specifications). If longer rise-time is expected it is recommended to use an external POR circuit attached to the RESET pin (see Application Note AN001). Slow VCC rise-time or short power interruptions may cause improper operation that is not handled by the internal POR. In this case the RESET should be activated in order to ensure proper start-up.

Important note on using OFF mode:

When turning the module OFF by setting ON/OFF low, great care should be taken to ensure proper power-on-reset (POR). Three alternatives can be used:

- Control the RESET pin by a separate I/O pin from the MCU using a 100 kOhm series resistor (RESET does not have any internal serial resistor). Set RESET low before

ON/OFF is turned low, and keep low until ON/OFF is high again ($V_{CC} - 10\%$). This will ensure proper power-on reset (POR).

- If a dedicated I/O pin for the RESET signal is not available, a 10 kOhm series resistor from ON/OFF to RESET can be used, and controlling ON/OFF with a 3 / 5V signal from the MCU. This is valid for the RC12x0-series only. For the RC10x0-modules direct control of the RESET-pin must be used
- Use an external POR and brown-out supervisory circuit. The circuit should be connected between VDD and GND, controlling RESET. This solution will force RESET low as long as VDD is below the threshold voltage. The RESET has an internal pull-up resistor to VDD, thus an open-drain output supervisory circuit can be used. A threshold voltage of 2.5 V is recommended. Supervisory circuits at 2.5V are for example MAX803 and MAX6328.

As noted in the Pin Description, RXEN (CTS/RXTX), TXEN (RTS) and CONFIG pins should have their pull-ups connected to VDD, not VCC. If RXEN is used as CTS (hardware handshake) or as RXTX (RS485) output, no pull-up is required and should be avoided as this reduce the voltage swing due to the internal resistor.

Timing Information

The figure and table below shows the timing information for the module when changing between different operating states.

The IDLE state is the normal state where the module search for preamble on the air and wait for a character to be received on the UART. RXD is the state when receiving characters from the host filling up the internal buffer. TX state is when the data is transmitted on the air. RX state is when data is received from the air after a preamble detection. TXD is the state where the received data is sent to the host on the UART.

CONFIG is the state entered by asserting the CONFIG pin and used during parameter configuration, while MEMORY CONFIG is the sub-state entered by the 'M' command where the configuration memory is being programmed.

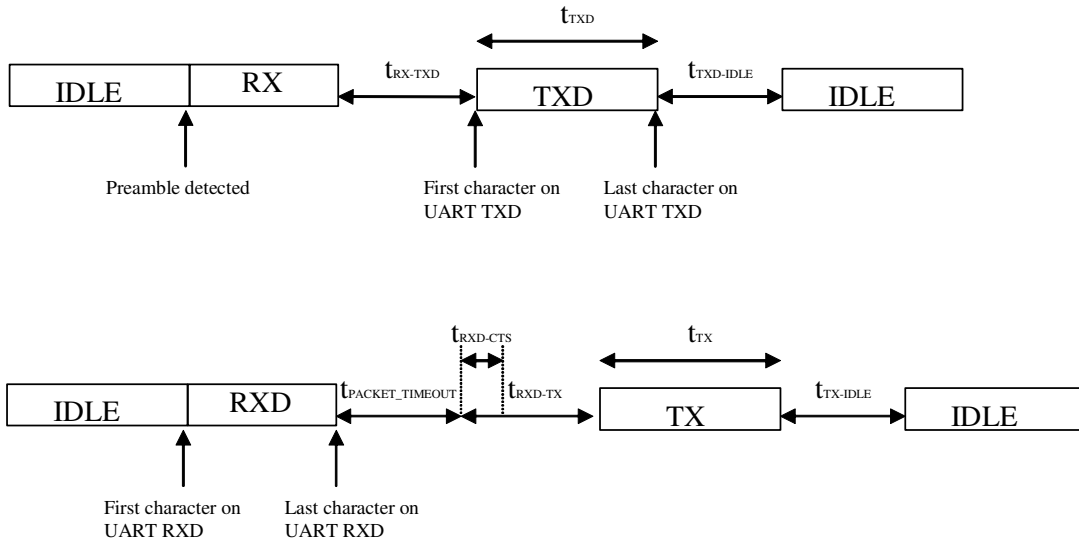

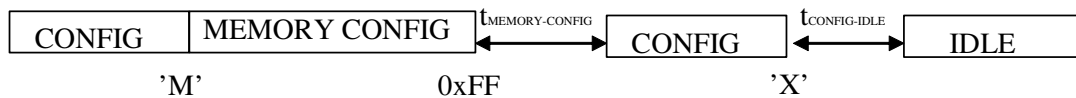
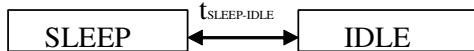
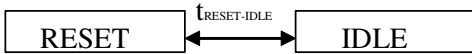
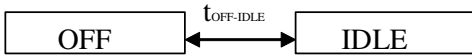

| Symbol | Value | Description / Note |
|----------------------|--------------|---|
| t_{RX-TXD} | 500 us | Time from last byte is received from the air until first character is sent on the UART |
| t_{TXD} | Min 621 us | $t_{TXD} = \# \text{ bytes received} \times 621 \text{ us/char}$ (10 bits at 19.2 kBd + 100 us delay per character) |
| $t_{TXD-IDLE}$ | 5 ms | Time from last character is sent on the UART until module is in IDLE mode (ready for RXD and RX) |
| $t_{PACKET-TIMEOUT}$ | Programmable | If enabled, the packet timeout can be configured from 32 ms to 4.08 s. If end character or fixed packet length is used, the timeout is 0 |
| $t_{RXD-CTS}$ | 25 us | Time from last character is received by the UART (including any timeout) until CTS is activated |
| t_{RXD-TX} | 1.3 ms | Time from last character is received by the UART (including any timeout) until the module sends the first byte on the air. |
| $t_{TX-IDLE}$ | 5 ms | Time from last character is sent on the air until module is in IDLE mode (ready for RXD and RX) |
| $t_{OFF-IDLE}$ | 160 ms | |
| $t_{RESET-IDLE}$ | 160 ms | |
| $t_{SLEEP-IDLE}$ | 55 ms | |
| $t_{C-CONFIG}$ | 43 ms | |
| $t_{MEMORY-CONFIG}$ | 66 ms | In this period the internal flash is programmed. <i>Do not reset, turn the module off, or allow any power supply dips in this period as it may cause permanent error in the Flash configuration memory. After 0xFF the host should wait for the '>' prompt before any further action is done to ensure correct re-configuration.</i> |
| $t_{CONFIG-IDLE}$ | 5 ms | |
| t_{TX} | Min 5.8 ms | $t_{TX} = \# \text{ bytes to send} \times 417\text{us/byte}$ (at 19.2 kbit/s). Add 13 overhead bytes if addressing and CRC is not used. Add additionally 2 extra bytes for addressing and 2 extra bytes for CRC if enabled. |

RF Frequency, Output Power Levels and Data Rates

The following table shows the available RF channels and their corresponding frequencies, and nominal output power levels.

| Model | RF channel | Output power | Data rate |
|--------|-----------------------|------------------|-----------------------|
| RC1040 | 1: 433.302 MHz | 1: -14 dBm | 1: 1.2 kbit/s |
| | 2: 433.711 MHz | 2: -6 dBm | 2: 2.4 kbit/s |
| | 3: 433.916 MHz | 3: 0 dBm | 3: 4.8 kbit/s |
| | 4: 434.092 MHz | 4: 6 dBm | 4: 9.6 kbit/s |
| | 5: 434.319 MHz | 5: 9 dBm | 5: 19.2 kbit/s |
| RC1080 | 1: 868.130 MHz | 1: -15 dBm | 1: 1.2 kbit/s |
| | 2: 868.297 MHz | 2: -10 dBm | 2: 2.4 kbit/s |
| | 3: 868.366 MHz | 3: -5 dBm | 3: 4.8 kbit/s |
| | 4: 868.800 MHz | 4: 0 dBm | 4: 9.6 kbit/s |
| | 5: 868.919 MHz | 5: 5 dBm | 5: 19.2 kbit/s |
| | 6: 869.021 MHz | | |
| | 7: 869.526 MHz | | |
| | 8: 868.840 MHz | | |
| RC1090 | 1: 903.0 MHz | 1: -15 dBm | 1: 1.2 kbit/s |
| | 2: 906.0 MHz | 2: -10 dBm | 2: 2.4 kbit/s |
| | 3: 909.0 MHz | 3: -5 dBm | 3: 4.8 kbit/s |
| | 4: 912.0 MHz | 4: -3 dBm | 4: 9.6 kbit/s |
| | 5: 915.0 MHz | 5: -1 dBm | 5: 19.2 kbit/s |
| | 6: 918.0 MHz | | |
| | 7: 921.0 MHz | | |
| | 8: 924.0 MHz | | |
| | 9: 927.0 MHz | | |

RF channel and output power level can be set using the configuration commands 'C' and 'P' respectively. The data rate is fixed at 19.2 kbit/s. The *default* RF channel and output power level can be set in the configuration memory by using the 'M' command setting RF_CHANNEL and RF_POWER. The default values are used after power ON and RESET. The default factory settings are shown in **bold** in the table above.

For more details on changing the RF channel, output power or data rate, refer to the RC232™ User Manual describing the configuration commands.

The use of RF frequencies and maximum allowed RF power is limited by national regulations. The RC1040 and RC1080 are complying with the applicable directives within the European Union. The RC1090 is pending approval under FCC for use in the US and Canada.

RSSI Output

The module provides an analogue Received Signal Strength Indicator (RSSI) signal at pin 19. This pin can be connected to an ADC to measure the received signal strength. The signal strength can be used as an indication of fading margin, or as a carrier sense signal to avoid collisions.

The RSSI voltage decreases with increased input signal strength. Typical RSSI voltage as a function of input signal strength is shown in the figure below.

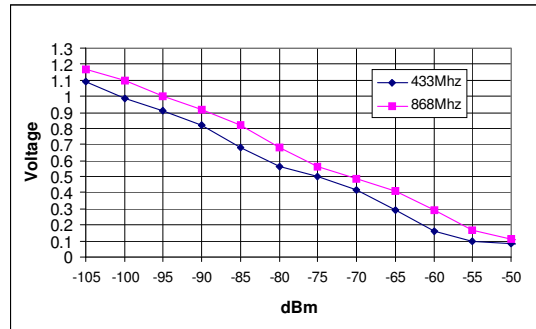

Antenna Connection

The antenna should be connected to the RF pin. The RF pin is matched to 50 Ohm. If the antenna connector is placed away from the module at the motherboard, the track between the RF pin and the connector should be a 50 Ohm transmission line.

On a two layer board made of FR4 the width of a microstrip transmission line should be 1.8 times the thickness of the board, assuming a dielectric constant of 4.8. The line should be run at the top of the board, and the bottom side should be a ground plane.

Example: For a 1.6 mm thick FR4 board, the width of the trace on the top side should be $1.8 \times 1.6 \text{ mm} = 2.88 \text{ mm}$.

The simplest antenna to use is the quarter wave whip antenna. A quarter wave whip antenna above a ground plane yields 37 Ohm impedance and a matching circuit for 50 Ohm are usually not required.

A PCB antenna can be made as a copper track where the ground plane is removed on the back side. The rest of the PCB board should have a ground plane as large as possible, preferably as large as the antenna itself, to make it act as a counterweight to the antenna. If the track is shorter than a quarter of a wavelength, the antenna should be matched to 50 ohms.

The lengths of a quarter wave antenna for different operational frequencies are given in the table below.

| Frequency [MHz] | Length [cm] |
|-----------------|-------------|
| 433 | 16.4 |
| 868 | 8.2 |
| 915 | 7.8 |

PCB Layout Recommendations

The recommended layout pads for the module are shown in the figure below. All dimensions are in thousands of an inch (mil). The circle in upper left corner is an orientation mark only, and should not be a part of the copper pattern.

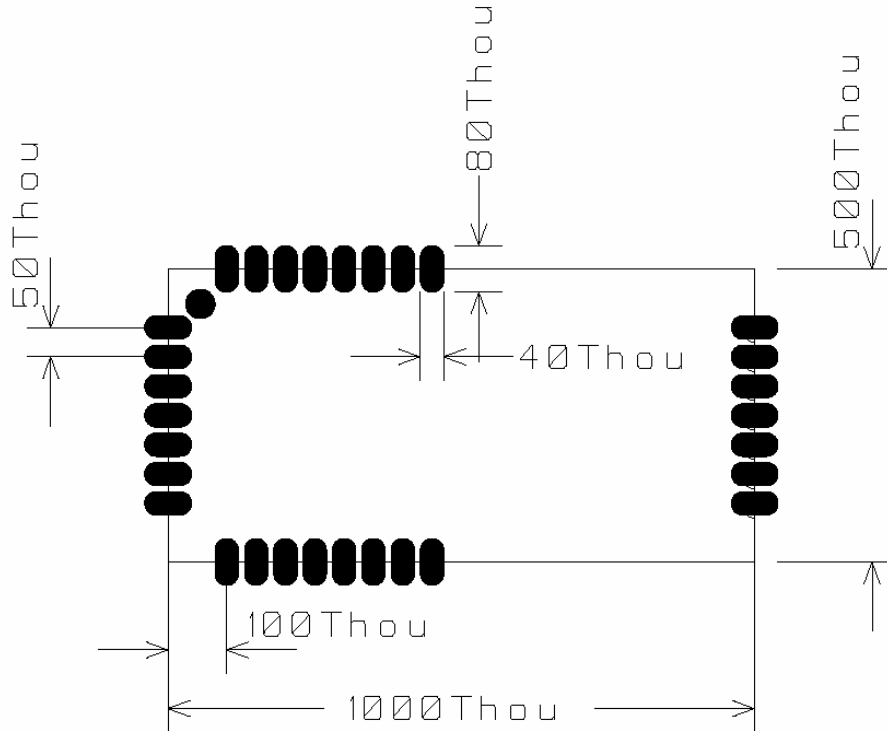

The area underneath the module should be covered with solder resist in order to prevent short circuiting the test pads on the back side of the module. A solid ground plane is preferred. Unconnected pins should be soldered to the pads, and the pads should be left floating.

Mechanical Drawing

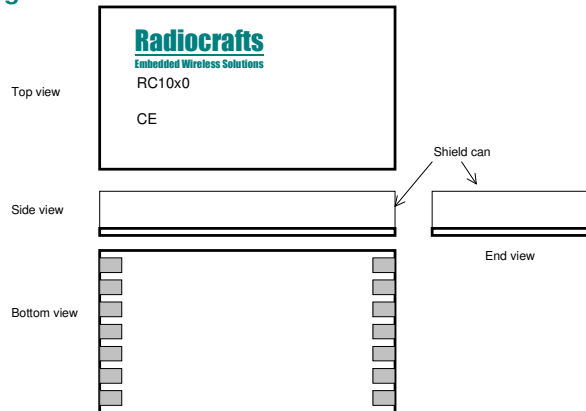

Drawings are not to scale

Mechanical Dimensions

The module size is 12.7 x 25.4 x 3.5 mm.

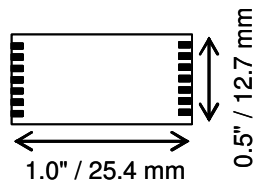

Carrier Tape and Reel Specification

Carrier tape and reel is in accordance with EIA Specification 481.

| Tape width | Component pitch | Hole pitch | Reel diameter | Units per reel |
|------------|-----------------|------------|---------------|----------------|
| 44 mm | 16 mm | 4 mm | 13" | Max 1000 |

Absolute Maximum Ratings

| Parameter | Min | Max | Unit |
|-----------------------|------|-----|------|
| Supply voltage, VCC | -0.3 | 5.5 | V |
| Voltage on any pin | -0.3 | 5.5 | V |
| Input RF level | | 10 | dBm |
| Storage temperature | -50 | 150 | °C |
| Operating temperature | -20 | 55 | °C |



Caution ! ESD sensitive device.
Precaution should be used when handling the device in order to prevent permanent damage.

Under no circumstances the absolute maximum ratings given above should be violated. Stress exceeding one or more of the limiting values may cause permanent damage to the device.

Electrical Specifications

T=25°C, VCC = 3.0V if nothing else stated.

| Parameter | Min | Typ. | Max | Unit | Condition / Note |
|--|-------------------------|----------------------|--------------------------|--------|---|
| Operating frequency RC1040 RC1080 RC1090 | 433.050 868.0 902 | | 434.790 870.0 928 | MHz | |
| Number of channels RC1040 RC1080 RC1090 | | 5 8 9 | | | |
| Input/output impedance | | 50 | | Ohm | |
| Data rate | | 19.2 | | kbit/s | |
| Frequency stability | | | +/-25 | ppm | |
| Transmit power RC1040 RC1080 RC1090 | -20 -20 -20 | 9 5 -1 | 9 5 -1 | dBm | Typical values are for default settings |
| FSK deviation | | +/-32 | | kHz | |
| Adjacent band power RC1040/RC1080 RC1090 | | | -37 -49 | dBm | |
| Occupied bandwidth | | 250 | | kHz | 99.5% |
| Spurious emission, TX RC1040/RC1080 < 1 GHz > 1 GHz RC1090 < 960 MHz > 960 MHz | | | -37 -30 -49 -41 | dBm | |
| Sensitivity RC1040 RC1080 RC1090 | | -95 -95 -95 | | dBm | |
| Blocking / Interferer rejection / desensitization +/- 1 MHz +/- 2 MHz +/- 5 MHz +/- 10 MHz | 30 35 50 60 | 43 49 68 72 | | dB | Wanted signal 3 dB above sensitivity level, CW interferer |

| | | | | | |
|---|-----------------|------------------|--------------------------|-----|--|
| Saturation | 10 | | | dBm | |
| Input IP3 | | -18 | | dBm | |
| Spurious emission, RX RC1040/RC1080 RC1090 | | | -57 -49 | dBm | |
| Supply voltage | 2.8 | | 5.5 | V | |
| Supply voltage rise time | | | 150 | us | If appropriate rise time can not be guaranteed, the RESET pin should be activated after supply voltage is stable. |
| Current consumption, IDLE/RX RC1040 RC1080 RC1090 | | 10.5 13 13 | | mA | Apply over entire supply voltage range |
| Current consumption, TX | | 25 | | mA | Apply over entire supply voltage range |
| Current consumption, SLEEP | | 85 | 150 | μA | Max value in bold apply over the entire temperature and supply voltage range |
| Current consumption, OFF | | 0.003 | 1.5 | μA | Max value in bold apply over the entire temperature and supply voltage range |
| Digital I/O Input logic level, low Input logic level, high Output logic level, low (1μA) Output logic level, high(-1μA) | 1.7 0 2.6 | | 0.7 5.5 0.1 2.7 | V | RXEN, TXEN, CONFIG, TXD and RXD have internal 100 kΩ series resistors. No internal pull-ups. Outputs should not be loaded resistively. |
| RESET pin Input logic level, low Input logic level, high | 1.7 | | 0.7 2.7 | V | Internal 100 kΩ pull-up resistor to VDD |
| ON/OFF pin Input logic level, low Input logic level, high | 1.4 | | 0.4 VCC | V | No internal pull-up resistor |

Document Revision History

| Document Revision | Changes |
|-------------------|--|
| 1.0 | First release |
| 1.1 | Minor editorial changes |
| 1.2 | Data buffer length changed from 200 to 128 Active polarity and RESET added in Pin description Added more information in the Pin description Added PCB layout recommendation Added carrier tape and reel specification Digital I/O specifications added in Electrical Specifications Updated Electrical Specifications Added timing information Minor corrections for clarity |
| 1.3 | Corrected table on data rate settings; data rate is programmable Timing information changed according to latest firmware upgrade (rev 1.16 and later) Minor spelling errors corrected, clarifications added Emphasized that some digital I/Os have 100 kOhm series resistors Note on VCC rise-time in the Power Management section Spurious emission in TX corrected in Electrical Specifications Added more information on power-on-reset when using ON/OFF |

Product Status Definitions

| Data Sheet Identification | Product Status | Definition |
|---------------------------|--|---|
| Preliminary | Engineering Samples and First Production | This data sheet contains preliminary data, and supplementary data will be published at a later date. Radiocrafts reserves the right to make changes at any time without notice in order to improve design and supply the best possible product. |

Disclaimer

Radiocrafts AS believes the information contained herein is correct and accurate at the time of this printing. However, Radiocrafts AS reserves the right to make changes to this product without notice. Radiocrafts AS does not assume any responsibility for the use of the described product; neither does it convey any license under its patent rights, or the rights of others. The latest updates are available at the Radiocrafts website or by contacting Radiocrafts directly.

As far as possible, major changes of product specifications and functionality, will be stated in product specific Errata Notes published at the Radiocrafts website. Customers are encouraged to check regularly for the most recent updates on products and support tools.

Trademarks

RC232™ is a trademark of Radiocrafts AS. The RC232™ Embedded RF Protocol is used in a range of products from Radiocrafts. The protocol handles host communication, data buffering, error check, addressing and broadcasting. It supports point-to-point, point-to-multipoint and peer-to-peer network topologies.

All other trademarks, registered trademarks and product names are the sole property of their respective owners.

Life Support Policy

This Radiocrafts product is not designed for use in life support appliances, devices, or other systems where malfunction can reasonably be expected to result in significant personal injury to the user, or as a critical component in any life support device or system whose failure to perform can be reasonably expected to cause the failure of the life support device or system, or to affect its safety or effectiveness. Radiocrafts AS customers using or selling these products for use in such applications do so at their own risk and agree to fully indemnify Radiocrafts AS for any damages resulting from any improper use or sale.

© 2005, Radiocrafts AS. All rights reserved.

Contact Information

Web site: www.radiocrafts.com

Email: radiocrafts@radiocrafts.com

Address:

Radiocrafts AS

Gunnar Schjelderups vei 11

NO-0485 OSLO

NORWAY

Tel: +47 970 86 676

Fax: +47 22 71 29 15

E-mail: sales@radiocrafts.com