

## PRODUCT SUMMARY

### Ultra low power, compact and low cost 2.4GHz transceiver

#### The nRF24L01

The nRF24L01 is a unique wireless solution for compact, battery operated applications with stringent requirements on battery lifetime and cost. The transceiver operates in the license free worldwide 2.4GHz ISM band.

It is specifically designed for two types of application: PC peripherals and ultra low power applications such as sports and wellness sensors. For PC peripherals such as wireless mice, keyboards and media center remotes it enables high performance and long battery life at a low solution cost. For sensor applications the ultra low power consumption and advanced power management enables battery lifetimes up to several years on a coin cell battery.

### Compact, highly integrated low cost solution

#### Compact 4x4mm package, low cost external BOM

The nRF24L01 integrates a complete 2.4GHz RF transceiver, an RF synthesizer, and full baseband logic including the unique Enhanced ShockBurst™ hardware link layer, advanced power management and a high-speed SPI for the host controller interface. No external loop filters, resonators or VCO varactor diodes are required, only a low cost  $\pm 60$ ppm 16MHz crystal, matching circuitry and the antenna.

### Block Diagram

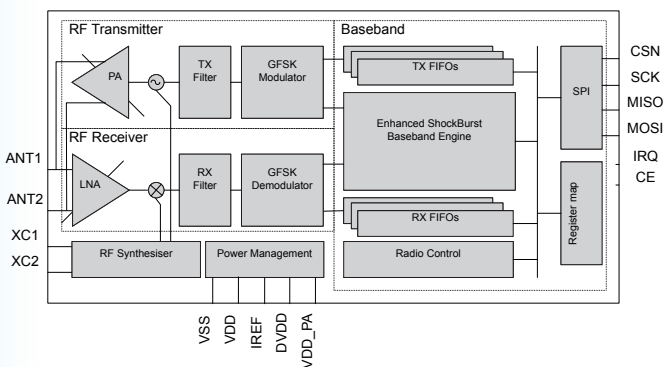

### Ultra low power consumption

#### A unique combination of high air data rate and advanced power management

The nRF24L01 has a unique combination of four features that enable the implementation of ultra-low power wireless connectivity:

- Sub 13mA TX and RX active currents that permit coin-cell battery operation
- Advanced power management with power saving idle modes combined with rapid active mode start-up from idle
- High 2 Mbps on-air data rate that allows the transceiver to minimize the time it spends in the relatively more power consuming active mode for a given effective data rate
- Enhanced ShockBurst™ link layer minimizes processing load on the host microcontroller reducing average current consumption

As a comparison, for a transceiver with the exact same specification, except lower air data rate, the approximate power penalty is as follows:

- |                        |                      |
|------------------------|----------------------|
| • 1 Mbps transceiver   | 2x power consumption |
| • 500 kbps transceiver | 4x power consumption |
| • 250 kbps             | 8x power consumption |



RF Silicon

Software

Reference Design

Development Tools

## PRODUCT BRIEF

### Nordic Semiconductor

# nRF24L01

## Single chip 2.4GHz Transceiver

### KEY FEATURES

- Worldwide 2.4GHz ISM band operation
- Up to 2 Mbps on-air data rate
- Ultra low power operation and advanced power management
- 11.3mA peak TX current at 0dB output power
- 12.3mA peak RX current at 2 Mbps air data rate
- 900nA in power down mode
- 22µA in standby mode
- On chip voltage regulator, 1.9 to 3.6V supply range
- Enhanced ShockBurst™ hardware link layer
- Automatic packet assembly (Preamble, Address and CRC)
- Dynamic payload length
- Selective auto acknowledgment with payload
- Auto retransmit
- 6 data pipe MultiCeiver™
- Air compatible with Nordic nRF2401A, 02, E1 and E2
- Low cost external  $\pm 60$ ppm 16MHz crystal
- 5V tolerant inputs
- Low cost chip inductors
- Compact 20-pin 4x4mm QFN package

### APPLICATIONS

- Wireless PC peripherals
- Mice, keyboards and remotes
- 3-in-one desktop bundles
- Advanced Media center remote controls
- VoIP headsets
- Game controllers
- Sports watches and sensors
- RF remote controls for consumer electronics
- Home and commercial automation
- Ultra low power sensor networks
- Active RFID
- Asset tracing systems
- Toys

### SUMMARY OF BENEFITS

- A true ultra low power solution enabled by a unique combination of low active mode currents, advanced power management and high air data rate
- A low cost solution is enabled by high level of integration with a minimum number of low cost external components
- Enhanced ShockBurst™ relaxes requirements and reduced load on the host microcontroller saving on both cost and power consumption

## Enhanced ShockBurst™ hardware link layer

### Enabling ultra low power, low cost system implementation

The nRF24L01 includes the Enhanced ShockBurst™ hardware link layer. It features both automatic packet handling and automatic packet transaction handling

#### Key features:

- Packet assembly
- Packet detection and validation
- Dynamic payload length
- Acknowledgment of received packages
- Payload in acknowledgment packet
- Retransmission of lost packages
- MultiCeiver™ provides 6 logical bi-directional data pipes for 1:6 star network topologies

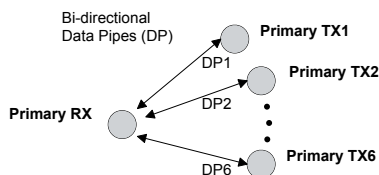

#### Main benefits:

- Enables implementation of robust, high performance bi-directional and unidirectional data links
- On chip hardware implementation maximizes data throughput while minimizing the time on-air which saves power and improves co-existence performance
- Relaxed requirements and reduced load on the host microcontroller saving both cost and power

#### For more information

Please visit [www.nordicsemi.no](http://www.nordicsemi.no) for complete product specification and more information about this and other products.

### About Nordic Semiconductor ASA

#### Ultra low power RF silicon solutions

Nordic Semiconductor is a fabless semiconductor company specializing in ultra low power short-range wireless communication. Nordic is a public company listed on the Norwegian stock exchange.

#### Nordic provides RF silicon solutions for ultra low power wireless including:

- Highly integrated RF silicon
- Sophisticated and flexible development tools
- Application specific communication software
- Complete reference designs

### Worldwide office locations

#### Headquarter

Trondheim, Norway

Telephone: +47 72 89 89 00

[www.nordicsemi.no](http://www.nordicsemi.no)

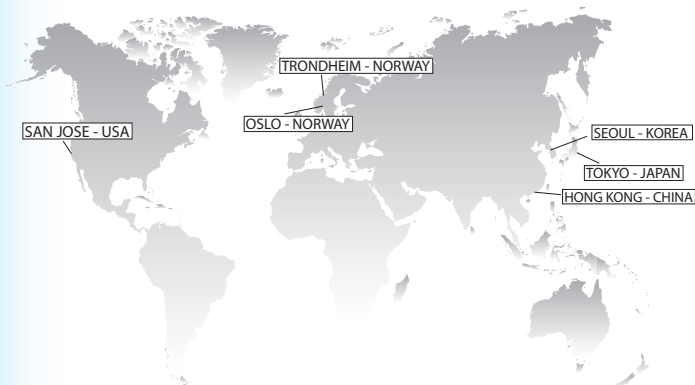

### SPECIFICATIONS

Frequency band	2.4GHz ISM ( 2.4000 – 2.4835GHz)
On-air data rate	1 or 2 Mbps
Modulation	GFSK
Channel bandwidth	1MHz for 1 Mbps mode 2MHz for 2 Mbps mode
RF channels	126
Output power	Programmable: 0, -6, -12 or -18dBm
External crystal	16MHz ±60ppm
Host Interface	High-speed SPI (up to 8 Mbps)
TX and RX FIFOs	3 separate 32 bytes TX and RX FIFOs
Hardware Link layer	Enhanced ShockBurst™ - Automatic packet assembly (Preamble, Address, CRC) - Automatic packet detection and validation - Dynamic packet length (1 to 32 bytes) - Auto acknowledgment with payload - Auto retransmit - 6 data pipe MultiCeiver™
Package options	RoHS compliant 20-pin 4x4mm QFN

### KEY ELECTRICAL SPECIFICATIONS

Parameter	Value	Unit
Minimum supply voltage	1.9	V
Maximum output power	0	dBm
Maximum air-data rate	2	Mbps
Sensitivity at 2Mbps	-82	dBm
Sensitivity at 1Mbps	-85	dBm
Supply current, TX at 0dBm	11.3	mA
Supply current, RX at 2Mbps	12.3	mA
Supply current, RX at 1Mbps	11.8	mA
Supply current, power down mode	900	nA
Supply current, standby mode	22	µA
Operating Temperature	-40 to +85	°C

### Related Products

nRF24L01-EVKIT	Complete evaluation kit for the nRF24L01
nRD24H1	RF remote control reference design
nRD24V1	Wireless voice VoIP headset reference design
nRF24LU1	Single chip 2.4GHz transceiver with USB, microcontroller and flash memory

Visit [www.nordicsemi.no](http://www.nordicsemi.no) for Nordic Semiconductor sales offices and distributors worldwide.