

**Integration Guide:
GSM0308IG002**

Enfora Enabler IIIG M2M Integration Guide

Version: 1.04

Enfora, Inc.
www.enfora.com

Document Title:	Enfora Enabler IIIGM2M Modem Integration Guide
Version:	1.04
Date:	02/15/2008
Status:	Released
Document Control ID:	GSM030IG002

General

All efforts have been made to ensure the accuracy of material provided in this document at the time of release. However, the items described in this document are subject to continuous development and improvement. All specifications are subject to change without notice and do not represent a commitment on the part of Enfora, Inc. Enfora, Inc. will not be responsible for any loss or damages incurred related to the use of information contained in this document.

This product is not intended for use in life support appliances, devices or systems where a malfunction of the product can reasonably be expected to result in personal injury. Enfora, Inc. customers using, integrating, and/or selling this product for use in such applications do so at their own risk and agree to fully indemnify Enfora, Inc. for any damages resulting from illegal use or resale.

Copyright

Complying with all applicable copyright laws is the responsibility of the user. Without limiting the rights under copyright, no part of this document may be reproduced, stored in or introduced into a retrieval system, or transmitted in any form or by any means (electronic, mechanical, photocopying, recording or otherwise), or for any purpose, without the express written permission of Enfora, Inc.

Enfora may have patents, patent applications, trademarks, copyrights or other intellectual property rights covering subject matter in this document. Except as expressly provided in any written license agreement from Enfora, the furnishing of this document does not give you any license to these patents, trademarks, copyrights or other intellectual property.

©2002, 2003, 2004, 2005, 2006, 2007, 2008 Enfora, Inc. All rights reserved.

Enabler and Spider are either registered trademarks or trademarks of Enfora, Inc. in the United States.

Table of Contents

1. SAFETY PRECAUTIONS	1
1.1. IMPORTANT SAFETY INFORMATION	1
2. REGULATORY COMPLIANCE FCC	1
2.1. INTEGRATION CONSIDERATIONS AND INSTALLATION REQUIREMENTS	1
2.2. DISCLAIMER	3
3. MANUAL OVERVIEW.....	4
3.1. REVISION HISTORY.....	4
3.2. REFERENCE DOCUMENTS	5
3.2.1. <i>Enfora Enabler IIIG Product Documentation</i>	5
3.2.2. <i>GSM Device Specifications</i>	6
3.2.3. <i>US Government</i>	6
3.2.4. <i>Federal Communications Commission (FCC)</i>	6
3.2.5. <i>FCC Office of Engineering and Technology (OET)</i>	6
3.2.6. <i>Industry Canada</i>	6
3.2.7. <i>Environmental Regulations</i>	6
3.2.8. <i>Mechanical Specifications</i>	7
3.2.9. <i>RF and EMI Specifications</i>	7
4. INTRODUCTION	8
4.1. PRODUCT OVERVIEW.....	8
4.2. KEY FEATURES OF THE ENABLER III MODULE	8
4.3. PROVIDING MULTI-BAND OPERATION	10
4.4. WIRELESS DATA APPLICATION POSSIBILITIES.....	10
4.5. SUMMARY OF FEATURES FOR THE ENABLER IIIG MODULE	11
4.6. GENERAL DESIGN GUIDELINES FOR UTILIZING ENFORA GSM MODULES	14
4.6.1. <i>Advanced tips for an RF friendly layout</i>	15
4.6.1.1. Ground Plane	15
4.6.1.2. Thermal Relief	15
4.6.1.3. Antenna and RF Signal Trace	17
4.6.1.4. Vbat Input	18
4.6.2. <i>Audio Reference Design</i>	20
4.6.2.1. Audio Schematics	20
4.6.2.2. Audio Layout	21
5. TECHNICAL SPECIFICATIONS	22
5.1. ENABLER IIIG MODULE BLOCK DIAGRAM	22
5.2. DETAILED PRODUCT SPECIFICATIONS	23
CLIMATIC: STORAGE AND TRANSPORTATION.....	23
MECHANICAL: STORAGE AND TRANSPORTATION.....	23
MECHANICAL: PROPOSED STANDARDS	23
ELECTROMAGNETIC EMISSIONS	23
5.3. OPERATING POWER	24
5.3.1. <i>Typical Input Current</i>	24
5.3.2. <i>GSM Transmit Power</i>	24
5.3.3. <i>GSM Receiver Sensitivity</i>	24
6. PHYSICAL INTERFACES	25
6.1. MODULE MOUNTING TO HOST BOARD (REFERENCE).....	29
6.2. CONNECTORS	32
6.3. RF CONNECTION OPTIONS	32
6.3.1. <i>Coaxial Connector Option</i>	32

6.3.2.	<i>RF Board-to-Board Connector Option</i>	32
6.3.3.	<i>I/O Connector Pin Assignments</i>	33
6.4.	CIRCUIT PROTECTION.....	35
6.5.	ANTENNA.....	36
6.6.	CONTROL CONNECTOR SIGNAL DESCRIPTIONS AND FUNCTIONS.....	36
6.6.1.	<i>Module Power (Pins 85, 87, 89, 91, 93, 95, 97, 99)</i>	36
6.6.2.	<i>Reset Signal (Pin 37)</i>	37
6.6.3.	<i>Power Control (Pin 35) (PWR_CTL)</i>	38
6.6.3.1.	Turning ON the Enabler IIIG.....	38
6.6.3.2.	Turning OFF the Enabler IIIG.....	38
6.6.3.3.	Using the Power Control Signal.....	39
6.6.4.	<i>Level Translation Reference Power (Pin 77)</i>	42
6.6.5.	<i>USB (Pins 1, 3, 5, 7, 9)</i>	42
6.6.6.	<i>General Purpose Input/Output Interface</i>	44
6.6.7.	<i>RTC Sleep</i>	45
6.6.8.	<i>Serial Interfaces & Handshake (Pins 11, 13, 15, 17, 19, 21, 23, 25)</i>	46
6.6.8.1.	Ring Indicate (Pin 23).....	46
6.6.9.	<i>MCSI – Multi-Channel Serial Interface (Pins 12, 14, 16, 18)</i>	48
6.6.10.	<i>VBACKUP Input (Pin 83)</i>	49
6.6.11.	<i>Using VBACKUP</i>	49
6.6.12.	<i>32 kHz output (Pin 56)</i>	49
6.6.13.	<i>13 MHz output (Pin 52)</i>	50
6.6.14.	<i>Analog-To-Digital Input (Pin 74)</i>	50
6.6.15.	<i>Handset Microphone Input (Pins 65, 67)</i>	50
6.6.16.	<i>Handset Microphone Bias Output (Pin 63)</i>	51
6.6.17.	<i>Handset Speaker Output (Pins 71, 73)</i>	51
6.6.18.	<i>Headset Microphone Input (Pin 55)</i>	52
6.6.19.	<i>Headset Microphone Bias Output (Pin 53)</i>	52
6.6.20.	<i>Headset Speaker Output Left & Right (Pins 57, 59)</i>	53
6.6.21.	<i>Headset Output Common Mode (Pin 61)</i>	53
6.6.22.	<i>Headset Detect (Pin 47)</i>	54
6.7.	SUBSCRIBER IDENTITY MODULE (SIM) CARRIER (PINS 76, 78, 80, 82, 84).....	55
6.7.1.	<i>SIM Integration for the Enfora Enabler IIIG Module</i>	55
6.7.2.	<i>Using a Remote SIM with the Enfora Enabler IIIG Module (Pins 76, 78, 80, 82, 84)</i>	55
6.7.2.1.	Remote SIM Component Information.....	57
7.	GSM/GPRS MODES OF OPERATION.....	58
7.1.	ENABLING THE TRANSMISSION MODES FOR THE GSM/GPRS SERVICES.....	58
7.2.	VOICE COMMUNICATION.....	58
7.3.	CIRCUIT-SWITCHED DATA.....	58
7.4.	SMS: SHORT MESSAGE SERVICES.....	59
8.	SIM OPERATION.....	60
8.1.	PROVISIONING THE SIM.....	60
8.2.	GSM SERVICES SUPPORTED BY THE ENFORA ENABLER IIIG MODULE.....	60
8.3.	GPRS SERVICES SUPPORTED BY THE ENFORA ENABLER IIIG MODULE.....	60
8.4.	SELECTING THE GSM MODES OF OPERATION.....	61
9.	SOFTWARE INTERFACE.....	62
9.1.	SOFTWARE INTERFACE.....	62
9.2.	FORMAT FOR THE AT COMMANDS.....	63
9.3.	ENFORA AT COMMAND SET.....	64
9.4.	ENFORA PACKET APPLICATION PROGRAMMING INTERFACE.....	64
9.4.1.	<i>API Architecture</i>	64
10.	SETUP AND INITIALIZATION.....	65

10.1.	GENERAL SETUP	65
10.1.1.	<i>HyperTerminal Configuration for Enabler IIIG module</i>	65
10.1.2.	<i>Initialization (AT Command Interface)</i>	66
10.1.3.	<i>Initial Response to the AT Command</i>	67
10.1.4.	<i>Sending an Initialization String to the Enfora Enabler IIIG Module</i>	67
10.1.5.	<i>Setting Up the Communication Mode for the Enfora Enabler IIIG Module</i>	68
10.1.6.	<i>Querying the Status of the Enfora Enabler IIIG Module</i>	69
10.1.7.	<i>Setting Module Reporting Parameters for GSM and GPRS</i>	69
10.2.	GSM/SMS EXAMPLES	69
10.2.1.	<i>Initialize the Enfora Enabler IIIG Module to Send and Receive SMS Text Messages</i>	69
10.2.2.	<i>Managing SMS Messages</i>	69
10.2.3.	<i>Data Call Configuration</i>	69
10.2.4.	<i>Voice Call Configuration</i>	69
10.3.	GPRS PACKET EXAMPLES	69
10.3.1.	<i>GPRS ATTACH and ACTIVATE</i>	69
10.3.2.	<i>Windows PPP Setup</i>	69
11.	INTEGRATION AND TESTING	70
11.1.	INTEGRATING THE ENFORA ENABLER IIIG MODULE.....	70
12.	APPENDIX A - LIMITED WARRANTY	72
12.1.	SCOPE.....	72
12.2.	HARDWARE	72
12.3.	SOFTWARE.....	72
12.4.	OTHER CONSIDERATIONS	73
13.	APPENDIX B - REGULATIONS AND COMPLIANCE	74
13.1.	GCF/PTCRB APPROVAL (FORMERLY FTA)	74
13.2.	ELECTROMAGNETIC COMPATIBILITY (EMC) AND SAFETY REQUIREMENTS.....	74
13.3.	EMC/SAFETY REQUIREMENTS FOR THE USA	74
13.4.	HUMAN EXPOSURE COMPLIANCE STATEMENT	75
13.5.	COMPLIANCE WITH FCC REGULATIONS.....	75
13.6.	UNINTENTIONAL RADIATORS, PART 15.....	76
13.7.	INTENTIONAL RADIATORS, PART 22 & 24.....	76
13.8.	INSTRUCTIONS TO THE ORIGINAL EQUIPMENT MANUFACTURER (OEM).....	77
13.8.1.	<i>OEM Responsibilities for All Products Containing the Enabler IIIG module</i>	79
13.8.2.	<i>Specific OEM Responsibilities for Portable Products and Applications</i>	80
13.8.3.	<i>Specific OEM Responsibilities for Mobile Products and Applications</i>	80
13.8.4.	<i>Specific OEM Responsibilities for Fixed Products and Applications</i>	80
13.9.	EMC/SAFETY REQUIREMENTS FOR THE COUNTRIES OF THE EUROPEAN UNION (EU).....	81
13.10.	EMC/SAFETY REQUIREMENTS FOR OTHER COUNTRIES	81
14.	APPENDIX C - GLOSSARY AND ACRONYMS.....	82
15.	APPENDIX D – TABLES AND FIGURES.....	84
16.	APPENDIX E - CONTACTING ENFORA.....	85

1. Safety Precautions

1.1. Important Safety Information

The following information applies to the devices described in this manual. Always observe all standard and accepted safety precautions and guidelines when handling any electrical device.

- Save this manual: it contains important safety information and operating instructions.
- Do not expose the Enfora Enabler IIIG product to open flames.
- Ensure that liquids do not spill onto the devices.
- Do not attempt to disassemble the product: Doing so will void the warranty. With the exception of the Subscriber Identification Module (SIM), this product does not contain consumer-serviceable components.

2. Regulatory Compliance FCC

2.1. Integration Considerations and Installation Requirements

The Enabler IIIG modem is designed for use in a variety of host units, "enabling" the host platform to perform wireless data communications. However, there are certain criteria relative to integrating the modem into a host platform such as a PC, laptop, handheld or PocketPC®, monitor and control unit, etc. that must be considered to ensure continued compliance with FCC compliance requirements.

- In order to use the Enabler IIIG modem without additional FCC certification approvals, the installation must meet the following conditions:

Maximum RF output power and antenna gain to meet Maximum Permissible Exposure Requirements: GSM850 mode: Power at antenna port is +32 dBm. The maximum gain is 4.5 dBi (2.35 dBd). GSM1900 mode: Power at antenna port is 31.3 dBm. The maximum gain is 2 dBi in order to meet the requirements of maximum 2 watts EIRP for mobile transmitters. If RF power and/or antenna gain is desired, a separate FCC certification is required.

- If used in a "portable" application such as a handheld or body worn device with the antenna less than 20 cm (7.9 in.) from the human body when the device is operating, then the integrator is responsible for passing additional "as installed" testing and the device will require it's own FCC ID:
 - SAR (Specific Absorption Rate) testing, with results submitted to the FCC for approval prior to selling the integrated unit. If unable to meet SAR requirements, then the host unit must be restricted to "mobile" use (see below).
 - Unintentional emissions, FCC Part 15; results do not have to be submitted to the FCC unless requested, although the test provides substantiation for required labeling (see below).
 - ERP and EIRP measurements for FCC Parts 22 and 24, alternatively a full retest on FCC Parts 22 and 24 can be performed

- If used in a "mobile" application where the antenna is normally separated at least 20 cm (7.9 in) from the human body during device operation, then an appropriate warning label must be placed on the host unit adjacent to the antenna. The label should contain a statement such as the following:

WARNING
RF exposure. Keep at least 20 cm (7.9 in) separation distance from the antenna and the human body.

- Host unit user manuals and other documentation must also include appropriate caution and warning statements and information.
- If the FCCID for the modem is not visible when installed in the host platform, then a permanently attached or marked label must be displayed on the host unit referring to the enclosed modem.

For example, the label should contain wording such as:

Contains GSM/GPRS modem transmitter module
FCC ID: MIVGSM0308
This device complies with Part 15 of the FCC Rules.
Operation is subject to the following two conditions: (1)
This device may not cause harmful interference, and (2)
This device must accept any interference received,
including interference that may cause undesired
operation.

OR

Contains FCC ID: MIVGSM0308
This device complies with Part 15 of the FCC Rules.
Operation is subject to the following two conditions: (1)
This device may not cause harmful interference, and (2)
This device must accept any interference received,
including interference that may cause undesired
operation.

- Any antenna used with the modem must be approved by the FCC or as a Class II Permissive Change (including MPEL or SAR data as applicable). The "professional installation" provision of FCC Part 15.203 does not apply.

- The transmitter and antenna must not be co-located or operating in conjunction with any other antenna or transmitter. Violation of this would allow a user to plug another transmitter in to the product and potentially create an RF exposure condition.

WARNING
The transmitter and antenna must not be collocated or operating in conjunction with any other antenna or transmitter. Failure to observe this warning could produce an RF exposure condition.

2.2. Disclaimer

The information and instructions contained within this publication comply with all FCC, GCF, PTCRB, R&TTE, IMEI and other applicable codes that are in effect at the time of publication. Enfora disclaims all responsibility for any act or omissions, or for breach of law, code or regulation, including local or state codes, performed by a third party.

Enfora strongly recommends that all installations, hookups, transmissions, etc., be performed by persons who are experienced in the fields of radio frequency technologies. Enfora acknowledges that the installation, setup and transmission guidelines contained within this publication are guidelines, and that each installation may have variables outside of the guidelines contained herein. Said variables must be taken into consideration when installing or using the product, and Enfora shall not be responsible for installations or transmissions that fall outside of the parameters set forth in this publication.

Enfora shall not be liable for consequential or incidental damages, injury to any person or property, anticipated or lost profits, loss of time, or other losses incurred by Customer or any third party in connection with the installation of the Products or Customer's failure to comply with the information and instructions contained herein.



The Enabler IIIG platform is designed with features to support a robust connection. There are instances where the module performance is beyond the control of the intended design. Integrated designs that require 24 by 7 operation must implement power control via an external circuit or by implementing power management as specified within this design guide.

3. Manual Overview

This document describes the available hardware interface of the Enabler IIIG modem. The purpose of this document is to define the electrical, mechanical and software interfaces while providing detailed technical information in order to streamline the process of hardware and system integration.

3.1. Revision History

Date	Rev	Author	Description
01/17/07	1.00	Tom Cone	Initial Release Draft
04/26/07	1.01	Tom Cone	Initial Release
07/03/07	1.02	Tom Cone	Modified Section 9.4 – Removed Modem Control Library Info Changed reference from GSM0000PB006MAN to GSM0308PB002MAN Replaced host board figures with updated figures Edited references to outdated documents
07/17/07	1.03	Sean Jones	Updated Table 2 Serial pin numbers
02/15/08	1.04	Sean Jones	SIMDTX, Low Power Mode, Table 2, GPIO4 Alt. description updates Edited Operating Temperature

3.2. Reference Documents

3.2.1. Enfora Enabler IIIG Product Documentation

Manuals

- GSM0308AT001 - Enfora GSM/GPRS OEM Module AT Command Set Reference
- GSM0308UG001 - Enfora GSM-GPRS Family API Reference

Application Notes

- GSM0000AN001 - Enabler-G PPP Configuration for Windows 98
- GSM0000AN002 - Enabler-G PPP Configuration for Windows 2000
- GSM0000AN003 - Enabler-G Data Circuit Switched Call Configuration and Use
- GSM0000AN004 - Enabler-G SMS Configuration and Use
- GSM0000AN005 - Enabler-G Automated Network Connection Configuration and Use
- GSM0000AN006 - Enabler-G Module Status Query
- GSM0000AN007 - Enabler-G Status Reporting
- GSM0000AN008 - Enabler-G PPP Configuration for Windows XP
- GSM0000AN009 - Dynamic IP Assignment Support
- GSM0000AN010 - Enabler-G PPP Configuration for PocketPC 2002
- GSM0000AN011 - PAD Configuration and Use
- GSM0000AN012 - Network Transparency Configuration for PAD
- GSM0000AN013 - Enabler-G Sleep Mode Configuration and Use
- GSM0000AN014 - Anytime PPP API Access
- GSM0000AN015 - Event Monitor and Reporting Overview
- GSM0000AN016 - How to Send SMS Messages to an E-Mail Address
- GSM0000AN017 - SMTP Mail Access via TCP PAD
- GSM0000AN018 - USNO NTP Network Time Service TCP PAD

Technical Notes

- GSM0000TN001 - Enabler-G Firmware Upgrade
- GSM0000TN002 - Enabler-G PPP Negotiation Sequence
- GSM0000TN006 - UDP Wakeup Message Header Decoding
- GSM0000TN008 - Enabler Power Supply Requirements
- GSM0000TN009 - Server Application Design Considerations for Dynamic IP
- GSM0000TN012 - Enabler IIIG Engineering Mode Command Reference
- GSM0000TN013 - Enabler IIIG and IIE CMUX Description

White Papers

- GSM0000WP001 - Enabler-G Differentiation Features

3.2.2. GSM Device Specifications

- 3GPP TS 51010-1 (850, 900,1800,1900 MHz devices)

To view the latest release, go to:

<http://www.3gpp.org/ftp/Specs/html-info/51010-1.htm>

3.2.3. US Government

3.2.4. Federal Communications Commission (FCC)

Internet: <http://www.fcc.gov/>

- FCC Rules, Part 24
 - 47 CFR Subpart E--Broadband PCS
 - 47 CFR § 24.52, sections 1.1307(b), 2.1091, and 2.1093
- FCC Rules, Part 22 for GSM 850
- FCC Rules, Part 15
- FCC Rules, Part 2
 - Subpart J--Equipment Authorization Procedures
 - Section 2.925

3.2.5. FCC Office of Engineering and Technology (OET)

Internet: <http://www.fcc.gov/oet/>

- Bulletin Number 65 "Evaluating Compliance with FCC Guidelines for Human Exposure to Radio Frequency Electromagnetic Fields"
- Supplement C "Additional Information for Evaluating Compliance of Mobile and Portable Devices with FCC Limits for Exposure to Radio Frequency Emissions"

3.2.6. Industry Canada

- RSS-132
- RSS-133
- ICES-003

3.2.7. Environmental Regulations

- National Environmental Policy Act (NEPA) of 1969 (Part 1, Subpart 1)

3.2.8. Mechanical Specifications

- ASTM D999
- ASTM D775
- IEC 68-2-27
- Bellcore Gr-63-CORE
- ETS 300 019-1-1 Class 1.2
- ETS 300 019-1-2 Class 2.1
- ETS 300 019-1-3 Class 3.1

3.2.9. RF and EMI Specifications

- ETSI Standards
- EN 61000-4-6
- EN 61000-4-3
- 3GPP TS 51.010-1, Section 12.2
- EN 55022 Class B

4. Introduction

4.1. Product Overview

Enfora Enabler IIIG modem is a compact, wireless OEM module that utilizes the Global System for Mobile Communications (GSM) and GPRS (General Packet Radio Services) international communications standard to provide two-way wireless capabilities via GSM services. The Enfora Enabler IIIG module is a fully Type-approved GSM/GPRS device, enabling application-specific, two-way communication and control.

The small size of the Enfora Enabler IIIG module allows it to be integrated easily into the application and packaging.

4.2. Key Features of the Enabler III Module

The following table summarizes the main features of the Enfora Enabler IIIG Radio Module.

Interface	Data input/output interface	100 position 0.4mm pitch connector
	Primary serial port	V.24 protocol, 1.8V levels, full 9-pin, UART implementation
	USB port	USB Debug only (Enfora Use only)
	GPIO	Up to 20 GPIO Some GPIO pins have dual purpose functionality.
	Audio	Digital audio via MCS1 port
	Voice	Supports four vocoder modes: full-rate (FR), enhanced full-rate (EFR), half-rate (HR), and adaptive multi-rate (AMR)
	Antenna Interface	ultra Miniature Coaxial Interconnect (MCD) or B2B Spring contact
	Command protocol	Enfora Packet API, GSM AT command set
	Subscriber Identification Module (SIM)	Optional 1.8/3 V mini-SIM carrier and interface on board with SIM detect
	Voltage backup	Voltage backup pin available to maintain RTC, battery capable
	Reference clock	32kHz and 13 Mhz. output reference clocks (accessible via 100-pin connector)
	ADC	1 ADC port
	Optional remote SIM	Accessible via the 100-pin connector
Power	Electrical power	3.3 to 4.5 Vdc (vbat)
	Peak currents and average power dissipation	Refer to the Operating Power table in the Technical Specifications for peak currents and average power dissipation for various modes of operation.
Radio Features	Frequency bands	EGSM 900, GSM1800, GSM 850 and GSM 1900 capability.
	GSM/GPRS features supported	Provides for all GSM/GPRS authentication, encryption, and frequency hopping algorithms. GPRS Coding Schemes CS1-CS4 supported. Multi-Slot Class 10 (4RX/2TX, Max 5 Slots).
Regulatory	Agency approvals	<ul style="list-style-type: none"> • GCF Type Approval • PTCRB Type Approval • FCC Certification • RTTE • CE (European Community Certification) • IC (Industry Canada) Approval

GSM/GPRS Functionality	<ul style="list-style-type: none"> • Mobile-originated and mobile-terminated SMS messages: up to 140 bytes or up to 160 GSM 7-bit ASCII characters. • Reception of Cell Broadcast Message • SMS Receipt acknowledgement • Circuit Switched Data (Transparent & Non-transparent up to 9.6 Kbps) • Voice (EFR, FR, HR) • Supports Unstructured Supplementary Service Data (USSD) • Multi-Slot Class 10 Supported (4Rx/2TX), (5 Slot Max) • PBCCH/PCCCH Supported
Audio Features	<ul style="list-style-type: none"> • Handset Microphone biasing • Headset Microphone biasing • Headset Plug/Unplug detection • Headset Hook detection (call answer/end button on equipped Headset microphone device) • High output dynamic differential Earphone mode, using Headset outputs • Pop Noise attenuation circuitry implemented for all single-ended output stages • Handset microphone input (MICIN, MICIP pins) • Headset microphone input (HSMIC pin)
Outputs	<ul style="list-style-type: none"> • Handset earphone outputs (EARP, EARN pins) • Headset 32 Ω stereo outputs (HSOL, HSOR pins)
SIM	1.8/3 V Mini-Subscriber Identity Module (SIM) compatible

Table 1 - Enabler IIIG Key Features

4.3. Providing Multi-Band Operation

The Enfora Enabler IIIIG module provides 4 frequency bands for compatibility with worldwide frequency standards. 850/1900 frequency bands are primarily used in North and South America, while 900/1800 bands are used through out the world. The Enabler III offers all four bands for use worldwide.

4.4. Wireless Data Application Possibilities

A variety of applications can use the Enfora Enabler IIIIG module for transmitting/receiving data/voice, such as:

- Automated Meter Reading (AMR)
- Point of Sale Applications
- E-mail and Internet access
- Automated Vehicle Location (AVL)
- Machine to Machine communication (M2M)
- Telematics
- Telemetry
- Wireless Security
- Smart Phones
- Telemedicine

4.5. Summary of Features for the Enabler IIIG Module

The following summarizes the main features of the Enfora Enabler IIIG Module.

Mechanical

Dimensions..... 27.0 mm x 28.0 mm x 2.50 mm
Weight 3.6g

Packet Data Transfer:

Protocol.....GPRS Release 97 and 99
Coding Schemes.....CS1-CS4
Multi-Slot Capability: (Demonstrated @MS10).....MS10 (4RX/2TX) (Max 5 Slots)
Packet Channel SupportPBCCH/PCCCH

Circuit Switched Data Transfer:

V110 300 bps/1200 bps/2400 bps/4800 bps/9600 bps/14,400 bps
Non-Transparent 300 bps/1200 bps/2400 bps/4800 bps/9600 bps/14,400 bps

Short Message Services:

GSM SMS MO, MT, CB, Text and PDU Modes
GPRS SMS MO, MT, CB, Text and PDU Modes

Voice Capability:

Speech Codec..... EFR, FR, HR, AMR

GSM/GPRS Radio Performance Multi-Band:

GSM0308 Radio Frequencies..... 850 MHz, 900 MHz, 1800 MHz, and 1900 MHz
Sensitivity <-106 dBm (Typical GPRS CS1)
850 & 900 MHz Transmit Power .. Class 4 (2 W)
1800 & 1900 MHz
Transmit Power Class 1 (1 W)

System Requirements:

Host Interface Serial Interface
DC Voltage 3.3 to 4.5 Vdc

Application Interface:

Host Protocol.....	Enfora Packet API and AT Commands
Internal Protocols	UDP stack, TCP/IP stack, PPP, PAD, and CMUX
Physical Interface.....	1 serial (primaryDefault rate auto baud,), I USB (debug) MCSI (PCM Audio only)
Audio Interface.....	Handset microphone input (MICIN, MICIP pins), Headset microphone input (HSMIC pin), Handset earphone outputs (EARP, EARN pins), Headset 32 Ω stereo outputs (HSOL, HSOR pins).

SIM Interface:

Remote SIM Option.....	1.8/3-Volt SIM Capability
------------------------	---------------------------

Environmental:

Compliant Operating Temp.	-20 °C to 60 °C (Fully GSM Spec Compliant)
Operating Temperature	-30 °C to 85 °C (This is the operating temperature – not fully GSM Spec Compliant)
Storage Temperature	-40 °C to 85 °C
Humidity	5 to 95% non-condensing

EMC:

Emissions	FCC Parts 15,22 & 24, Class B 3GPP TS 51010-1, Section 12.2 EN 55022 Class B
-----------------	--

Operating Power (TYPICAL):

GSM Operation

GSM 850/900 (1 RX/1 TX, full power).....	250 mA average, 1.6 A peak
GSM 1800 (1 RX/1 TX, full power).....	215 mA average, 1.3 A peak
GSM 1900 (1 RX/1 TX, full power).....	204 mA average, 1.2 A peak
Idle.....	<2.5 mA Average in DFX 5
Shutdown	<50uA

Vbat = 3.7V, Vbak=Vbat, current = 48uA
Vbat = 3.7V, Vbak=0V, current = 45uA
Vbat = 0V, Vbak=3.7V, current = 6uA

GPRS Operation Power

EGSM 850/900 (4 RX/1 TX, full power).....	272 mA average, 1.6 A peak
EGSM 850/900 (2 RX/2 TX, full power).....	420 mA average, 1.6 A peak
GSM 1800 (4 RX/1 TX, full power).....	242 mA average, A peak
GSM 1800 (2 RX/2 TX, full power)	354 mA average, A peak
GSM 1900 (4 RX/1 TX, full power).....	235 mA average, A peak
GSM 1900 (2 RX/2 TX, full power).....	340 mA average, A peak
Idle.....	<2.5 mA average in DFX 5

Shutdown<50uA
Vbat = 3.7V, Vbak=Vbat, current = 48uA
Vbat = 3.7V, Vbak=0V, current = 45uA
.....
Vbat = 0V, Vbak=3.7V, current = 6uA

GSM Transmit Power

1800/1900 MHz..... GSM Power Class 1 (30 dBm ± 2 dB @ antenna connection)
850/900 MHz..... GSM Power Class 4 (33 dBm ± 2 dB @ antenna connection)

GSM/GPRS Receiver Sensitivity (Typical)

1800/1900 MHz..... <-106 dBm, GPRS Coding Scheme 1 (CS1)
850/900 MHz..... <-106 dBm, GPRS Coding Scheme 1 (CS1)

4.6. General design guidelines for utilizing Enfora GSM modules

The following guidelines are provided in an effort to allow Enabler IIIG module users to successfully implement their PCB layout to obtain the best performance. This includes the lowest possible EMI emissions, maximum thermal conduction, mechanical integrity, and voice quality. The Enabler IIIG module is a very compact, high performance design, yet it is easy to interface into the final product. In order to realize its full potential, designers should pay close attention to ground structures, the routing of RF and Digital traces, and the size of the power supply lines.



These design tips are strictly guidelines and are not meant to be a complete list of items that guarantee actual performance. Each application is different and may require variation from these guidelines, however, care should be given to utilize these sound engineering principles whenever possible.

4.6.1. Advanced tips for an RF friendly layout

4.6.1.1. Ground Plane

To ensure the lowest possible EMI emissions and maximum thermal conductivity, it is recommended that all metal tabs on the GSM module shield must be soldered down onto a continuous ground plane that runs under the entire module. Ample ground vias should be provided around the metal tabs to create a low impedance ground. It is recommended to minimize the number of I/O and power traces and vias under the GSM module to allow for as much ground plane as possible. An example of a good ground structure and pad layout is shown below in Figure 1.

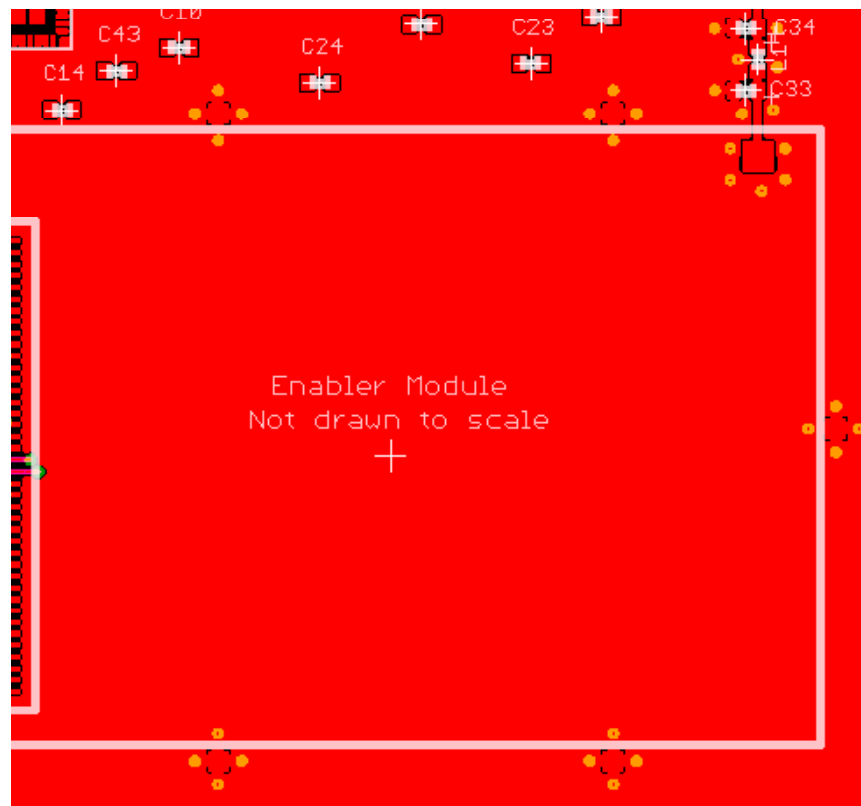

Figure 1 - Example of good ground plane for GSM modules

4.6.1.2. Thermal Relief

Because the ground plane acts as a large heat sink, it can affect the solderability of components. A common method to reduce this effect is to use thermal relief around the pad in question. However, great care must be taken when using thermal relief for high current or high frequency applications

For example, a large thermal relief like the one shown in Figure 2 can serve the purpose for general applications such as low current, low speed data lines, DC connections and audio

frequency applications. However, such thermal relief structures should be avoided for applications where high current and/or high frequency is involved, such as those using the Enabler Module. Depending on the frequency of operation, the long narrow thermal relief traces between the pad and the ground plane act like an RF choke. These RF chokes become higher impedance at harmonics of the fundamental frequency making it problematic for high frequency suppression. This can make it difficult to pass type approval testing.

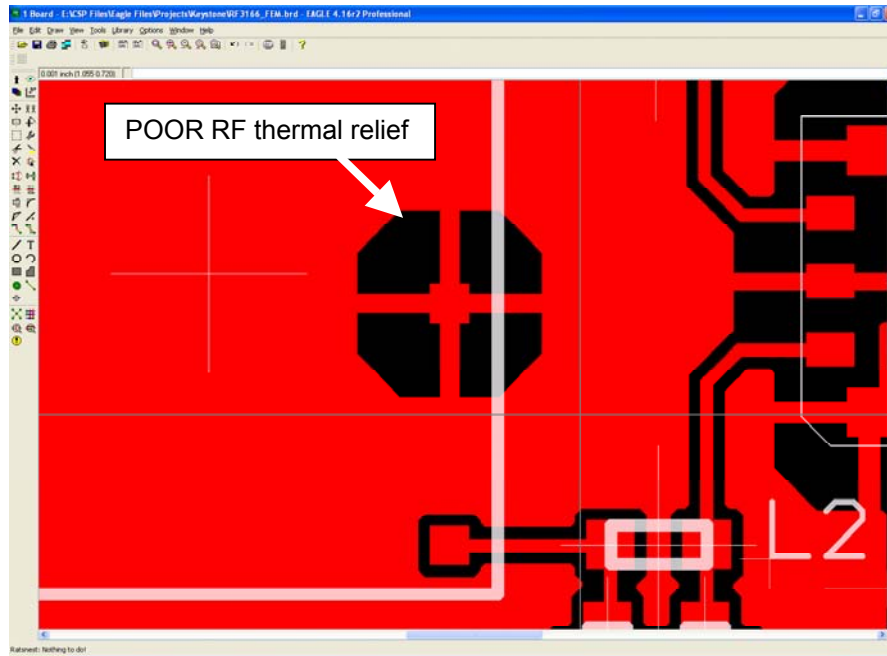

Figure 2 - Example of a POOR RF Thermal Relief

If thermal relief is necessary, it is recommended that you use short, fat traces similar to those shown in Figure 3. This will still provide a solderable connection, while providing a better RF connection. Making them shorter also allows for a more continuous ground plane due to less copper being removed from the area. It is also recommended to have ground vias around all thermal relief of critical ground pins such as the five Enabler shield tabs.

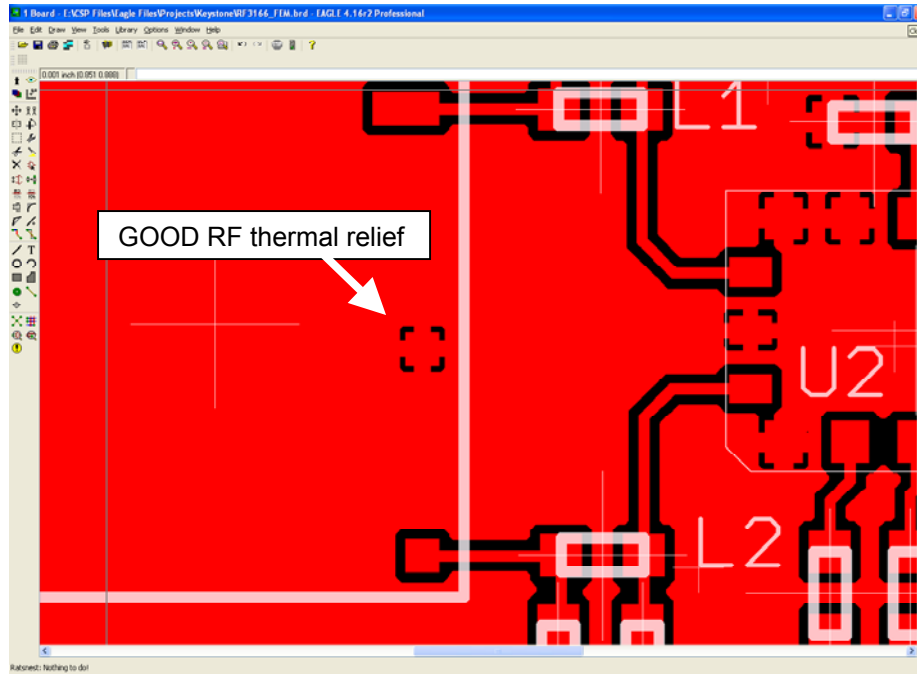

Figure 3 - Example of a GOOD RF Thermal Relief

4.6.1.3. Antenna and RF Signal Trace

The PCB trace that feeds the RF output port must be designed for a 50 ohm characteristic impedance, coplanar, or routed into internal layers to keep the top layer continuous around and underneath the Enabler module. Ample ground vias should be provided around the RF contacts, the RF trace and launch pad. If possible, keep I/O and power traces away from the RF port. This includes traces running parallel or orthogonal to it. Thermal relief should not be used on the antenna output port ground pads. The designer must pay close attention to the size of the pad and thickness of the dielectric beneath the signal pad and trace. Most PCB manufacturers can adjust the trace width to maintain 50 ohms impedance if the traces are identified and instructions are included on the FAB drawing. This service is typically provided at no or minimal additional cost.

For minimum RF emissions due to the fundamental frequency of operation, the Enabler module works best with an antenna load that has a VSWR of 1.5:1 or better. The antenna should not have gain at the harmonic frequencies, otherwise, the conducted harmonics could get amplified to a point where the product no longer passes type approval. However, for applications where antenna quality is less than ideal, it is recommended to have a low pass filter (Pi structure with N=3) in the RF path to the antenna. This is a secondary plan should there be a need to lower harmonic levels at frequencies above the PCS band. The pad structure may also be used to match the antenna load impedance, if required. If it is not needed, a capacitor of low reactance may be used to bridge the Pi structure.

The RF cable going between the Enable module and the antenna is very lossy, therefore, the length of this cable should be kept as short a possible.

4.6.1.4. Vbat Input

The Enabler Vbat input can have a relative high current draw that can fluctuate rapidly, especially when transmitting at max power and burst mode. The Vbat interface must be designed to provide the required instantaneous voltage and current with minimal voltage droop. This includes both sufficient bulk decoupling capacitance as well as adequate layout provisions.

When laying out the connections to the Enabler interface connector, it is tempting to use traces of the same width as the connector pins. However, this is a very compact connector and traces of that width will not have sufficient copper. Similar to the discussion on thermal relief, the use of narrow traces to connect the Vbat pins to the source voltage can act like a high impedance and cause a significant voltage droop when higher currents are required as shown in Figure 4.

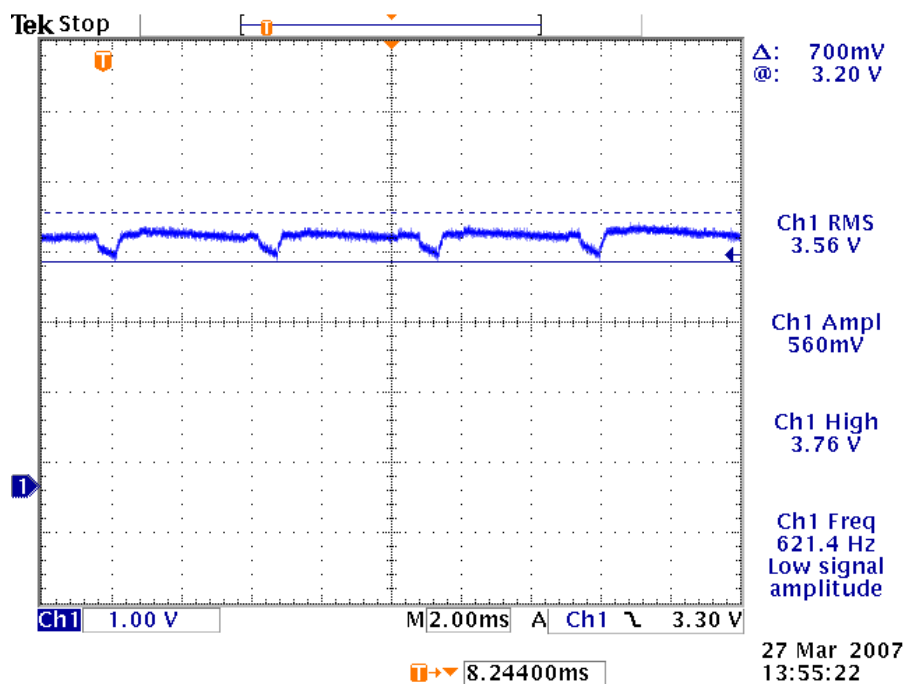

Figure 4 - Example of Vbat Voltage Droop

If the Vbat drops too low, the Enabler modules will reset. To minimize the trace loss, it is suggested to use a larger trace that spans several pins as shown in Figure 5. Any concern about solderability can be mitigated by using solder mask with cutouts for the individual pins as shown by the blue lines in the figure. The layout should provide sufficient trace width over the entire trace from the Enable modules all the way to the source of the Vbat voltage. Any transitions between layers for this trace should utilize multiple vias.

Since even the best layout will have some impedance from the source to the Enabler module, sufficient bulk decoupling capacitance is required at the Vbat input to the Enabler module. It is suggested to use at least two 1000 uF, low ESR, tantalum capacitors located very close to the Enabler interface connector Vbat pins. Any thermal relief used on these capacitors should comply with the information given above in order to provide the lowest impedance possible. The grounding of these capacitors is critical. Therefore, it should be a low

impedance and should utilize multiple vias to the internal ground plane close to the capacitor as well.

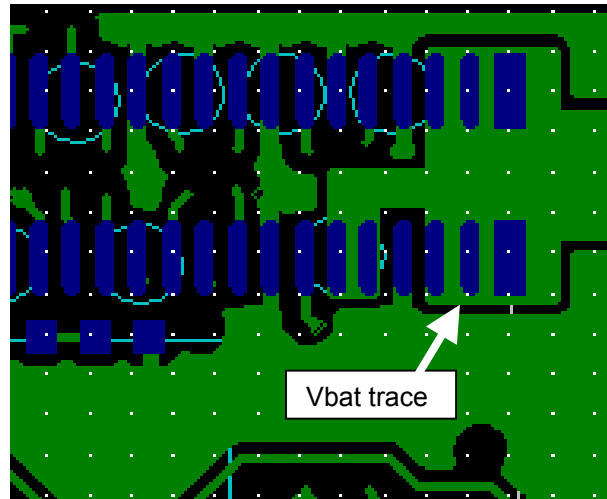

Figure 5 - Example of GOOD Vbat layout

4.6.2. Audio Reference Design

The audio quality is very dependent on the circuit design and layout. As an aid to obtaining good audio quality, a reference design has been included below. It has been proven to provide good performance on the SDK module.

4.6.2.1. Audio Schematics

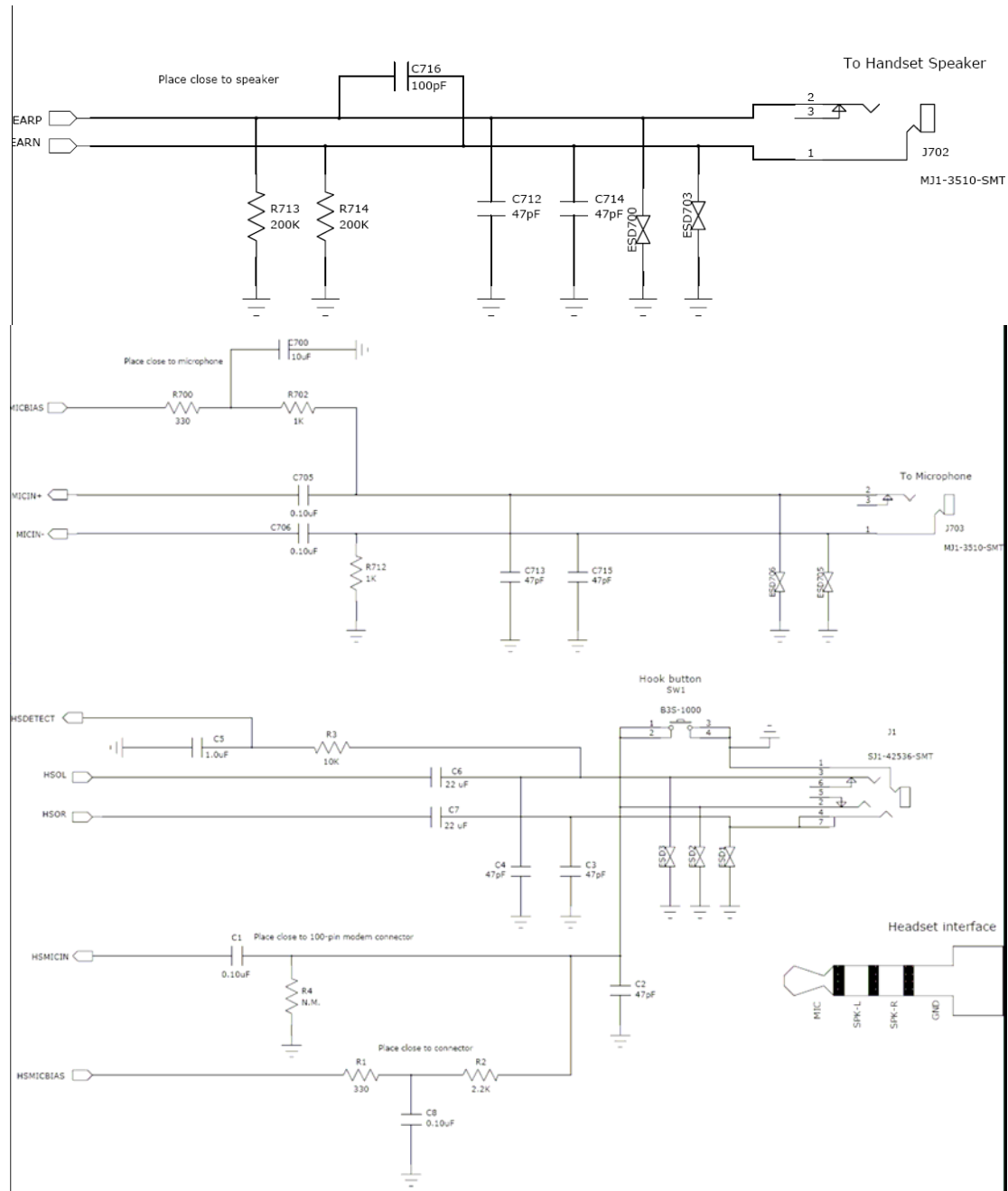

Figure 6 - Audio Reference Design Schematic

4.6.2.2. Audio Layout

Layout plots for the audio section of the SDK are available upon request.

5. Technical Specifications

5.1. Enabler IIIG Module Block Diagram

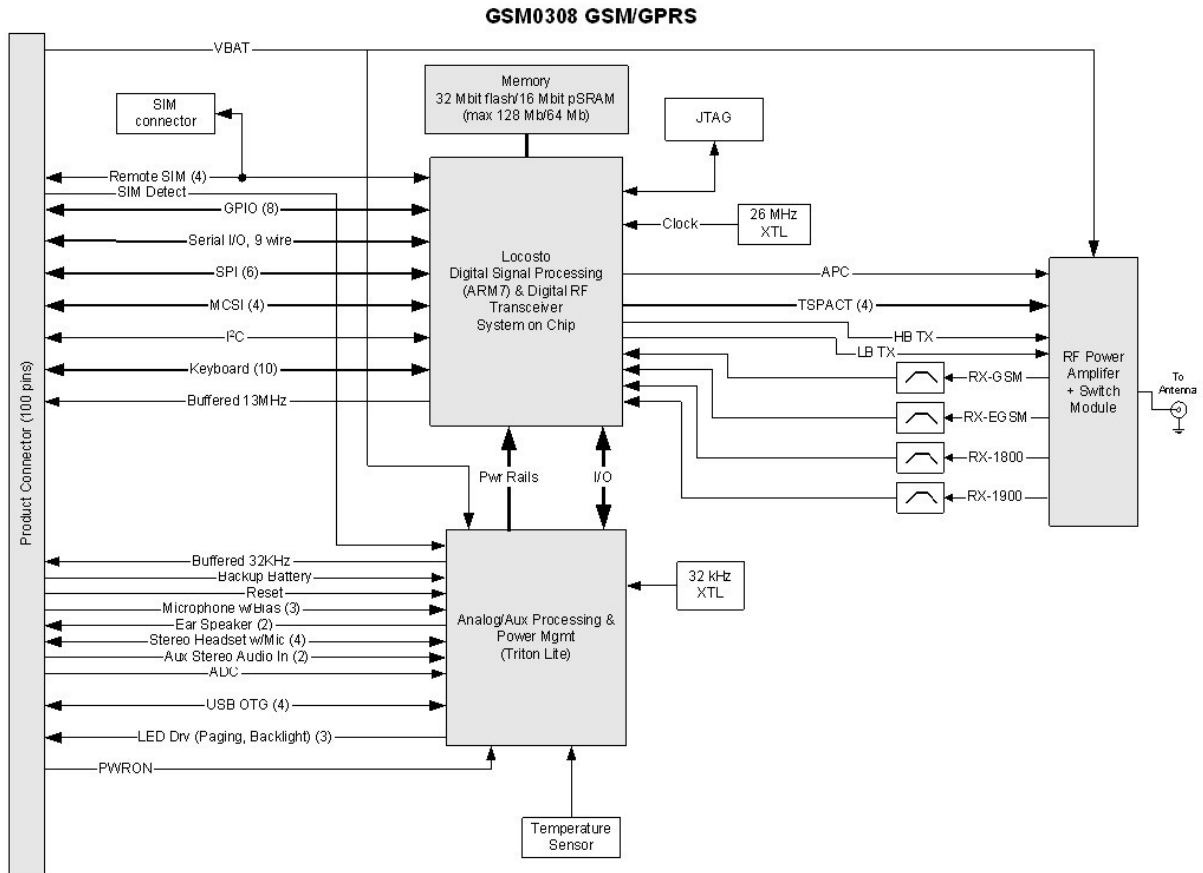

1/26/07

Figure 7 - Enabler IIIG Module Block Diagram

5.2. Detailed Product Specifications

Physical Dimensions and Weight	
Size (L x W x H)	27.0 mm x 28.0 mm x 2.50 mm
Weight	Without SIM Connector – < 3.6 grams With SIM Connector (no SIM inserted) – < 4.2 grams

Climatic: Operational	
GSM Compliant temperature Operating temperature	-20°C to +60°C -30°C to +70°C
Relative humidity	5 - 95%
Air pressure (altitude)	70 kPa to 106 kPa (-400 m to 3000 m)

Climatic: Storage and Transportation	
Duration	24 months
Ambient temperature	-40°C to +85°C
Relative humidity	5% to 95%, non condensing (at 40C)
Thermal shock	-50°C to +23°C, +70°C to +23°C; < 5 min
Altitude	-400 m to 15,000 m

Mechanical: Operational	
Operational vibration, sinusoidal	3.0 mm disp, 2 to 9 Hz; 1 m/s ² , 9 to 350 Hz
Operational vibration, random	0.1 m ² /s ³ , 2 to 200 Hz

Mechanical: Storage and Transportation	
Transportation vibration, packaged	ASTM D999
Drop, packaged	ASTM D775 method A, 10 drops
Shock, un-packaged	150 m/s ² , 11 ms, half-sine per IEC 68-2-27
Drop, un-packaged	4-inch drop per Bellcore GR-63-CORE

Mechanical: Proposed Standards	
Transportation	ETSI Standard ETS 300 019-1-2 Class 2.3 Transportation
Operational	ETSI Standard ETS 300 019-1-3 Class 3.1 Operational
Storage	ETSI Standard ETS 300 019-1-1 Class 1.2 Storage

Electromagnetic Emissions	
Radiated spurious	FCC Part 22 & 24 / Part 15 Class \ B 3GPP TS 51.010-1 Section 12.2 EN 55022 Class B

5.3. Operating Power

The Enfora Enabler IIIG module requires an input voltage of 3.3 Vdc to 4.5 Vdc.

5.3.1. Typical Input Current

Test Conditions:

Typical Results @ 3.8 V, 20 deg C, with 2000 μ F at connector input on V_{BAT} and RF terminated into a 50 Ω resistive load.

GSM Operation		Input Current			
Band	Mode	Low	Nom/Avg	High/Peak	Units
1900	1 RX/1 TX, Full Power	21	204	1180	mA
1800		21	215	1280	mA
900		21	248	1600	mA
850		21	250	1600	mA
ALL	Idle	600uA	2.4mA	154mA	
N/A	Shutdown		<50uA		

GPRS Operation		Input Current			
Band	Mode	Low	Nom/Avg	High/Peak	Units
1900	4 RX/1TX, Full Power	15	235	1180	mA
	2 RX/2TX, Full Power	15	340	1180	mA
	1 RX/1TX, Full Power	15	192	1180	mA
1800	4 RX/1TX, Full Power	15	242	1280	mA
	2 RX/2TX, Full Power	15	354	1280	mA
	1 RX/1TX, Full Power	15	201	1280	mA
900	4 RX/1TX, Full Power	15	272	1600	mA
	2 RX/2TX, Full Power	15	422	1600	mA
	1 RX/1TX, Full Power	15	232	1600	mA
850	4 RX/1TX, Full Power	15	268	1600	mA
	2 RX/2TX, Full Power	15	420	1600	mA
	1 RX/1TX, Full Power	15	231	1600	mA
ALL	Idle	600uA	2.4mA	140mA	
N/A	Shutdown		<50uA		

5.3.2. GSM Transmit Power

Enfora Enabler IIIG module	Power Class	Transmit Power
1900 MHz 1800 MHz	GSM Power Class 1	1-W conducted power maximum (30 dBm +/- 2 dB), measured at the antenna port
850 MHz 900 MHz	GSM Power Class 4	2-W conducted power maximum (33 dBm +/- 2 dB), measured at the antenna port

5.3.3. GSM Receiver Sensitivity

Enfora Enabler IIIG module	Sensitivity	Mode
1900 MHz 1800 MHz	-106 dBm (typical)	GPRS Coding Scheme 1 (CS1)
900 MHz 850 MHz	-106 dBm (typical)	GPRS Coding Scheme 1 (CS1)

6. Physical Interfaces

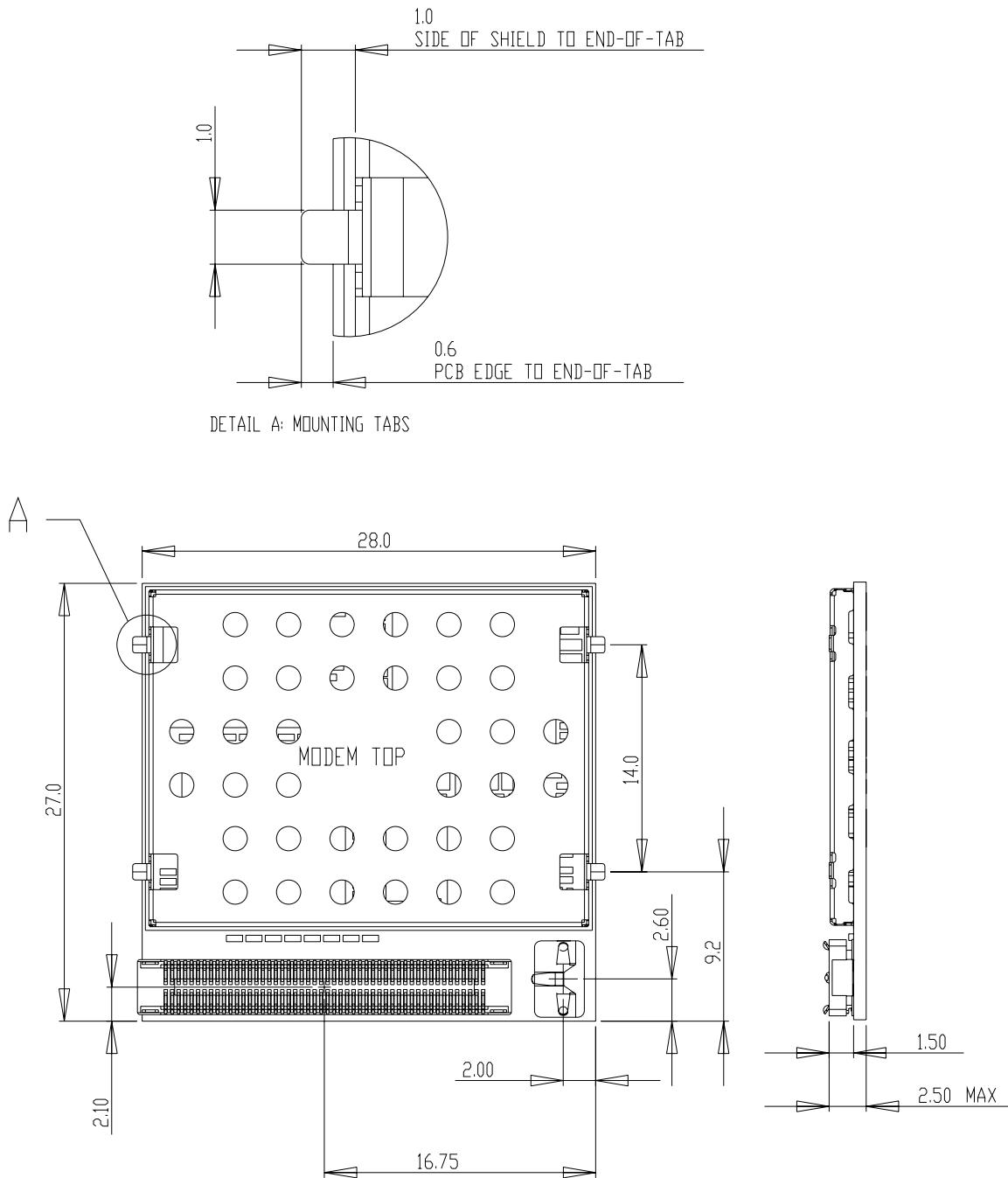

(Dimensions are in millimeters.)

Figure 8 – Front of Module (Board-to-Board RF Conn. Version)

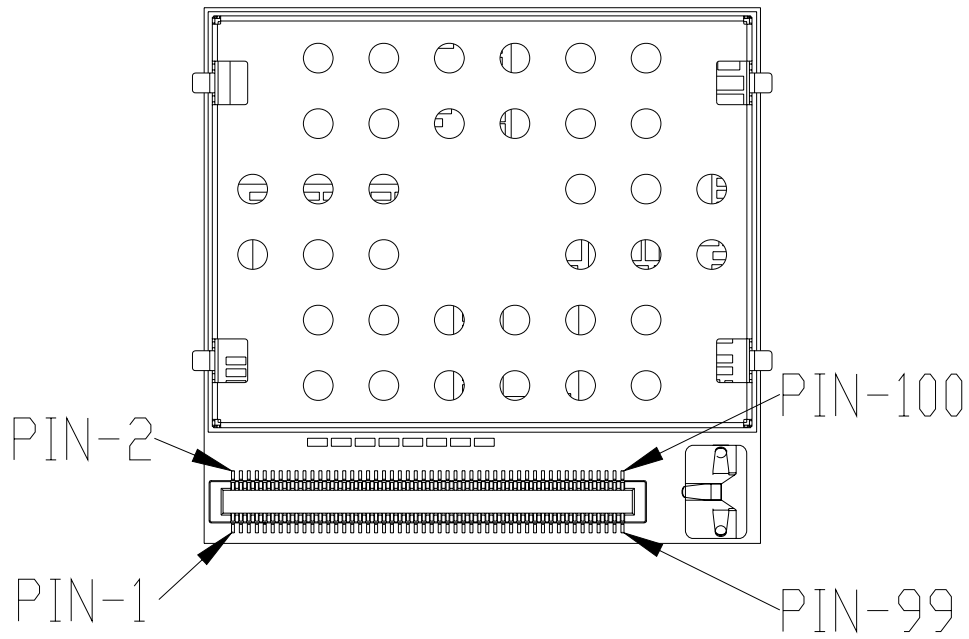

Figure 9 - Pin 1 Reference, 100-Pin I/O Connector

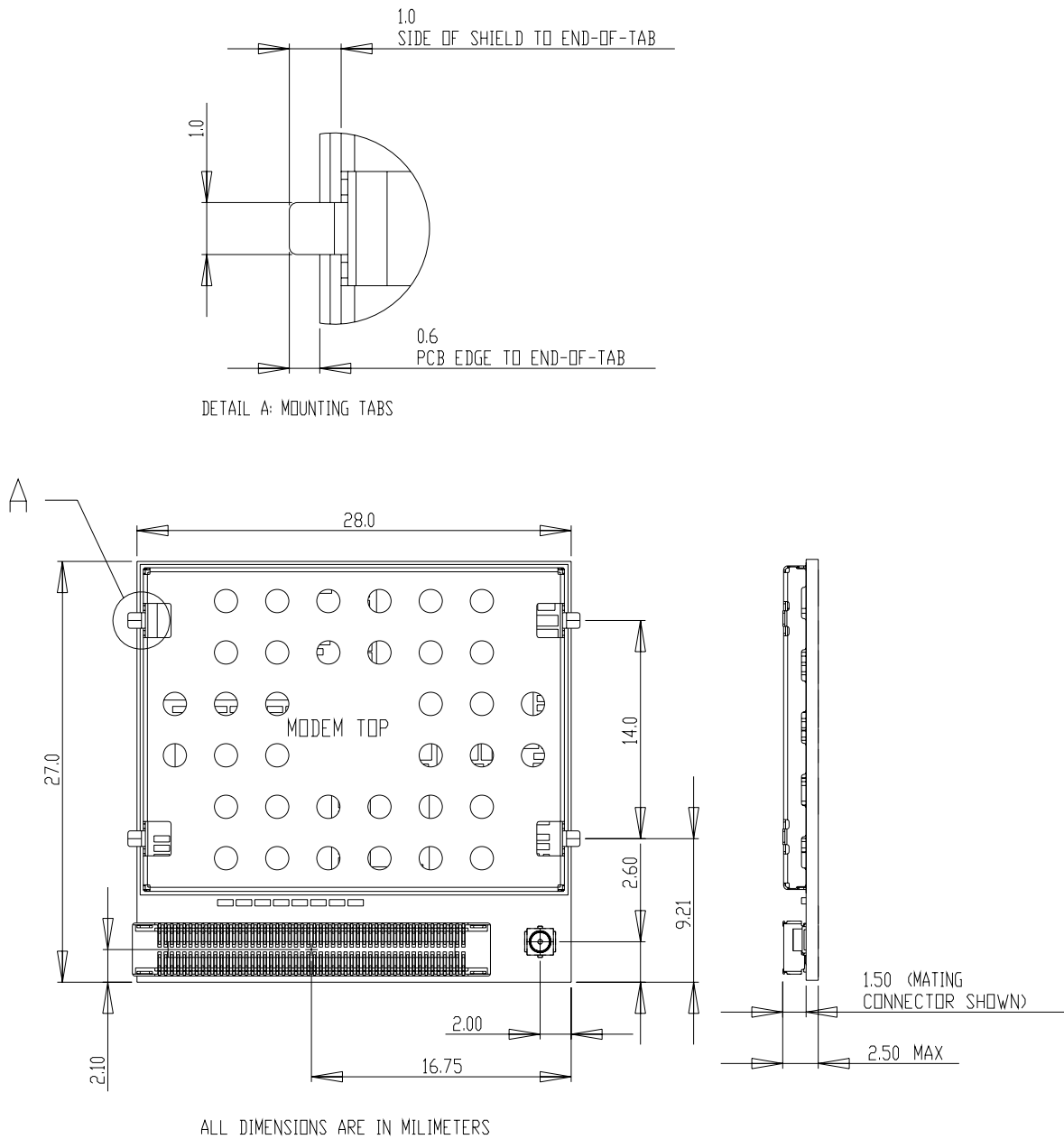

Figure 10 – Front of Module (Coaxial RF Conn. Version)

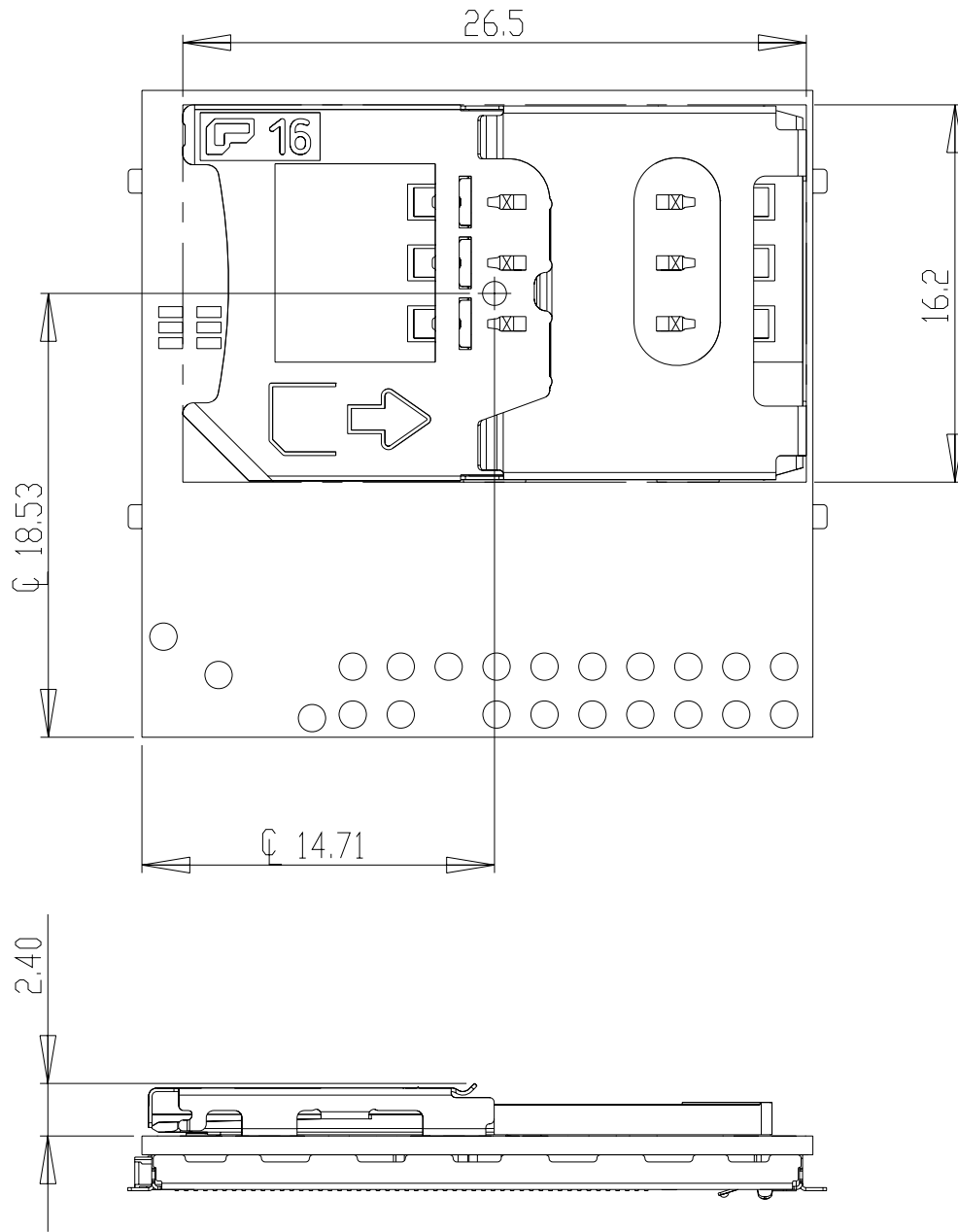

Figure 11 - Back of Module (Option SIM Shown)

6.1. Module Mounting to Host Board (Reference)

The module provides mounting tabs that **must** be soldered to a PCB. These tabs provide circuit grounding for the module.

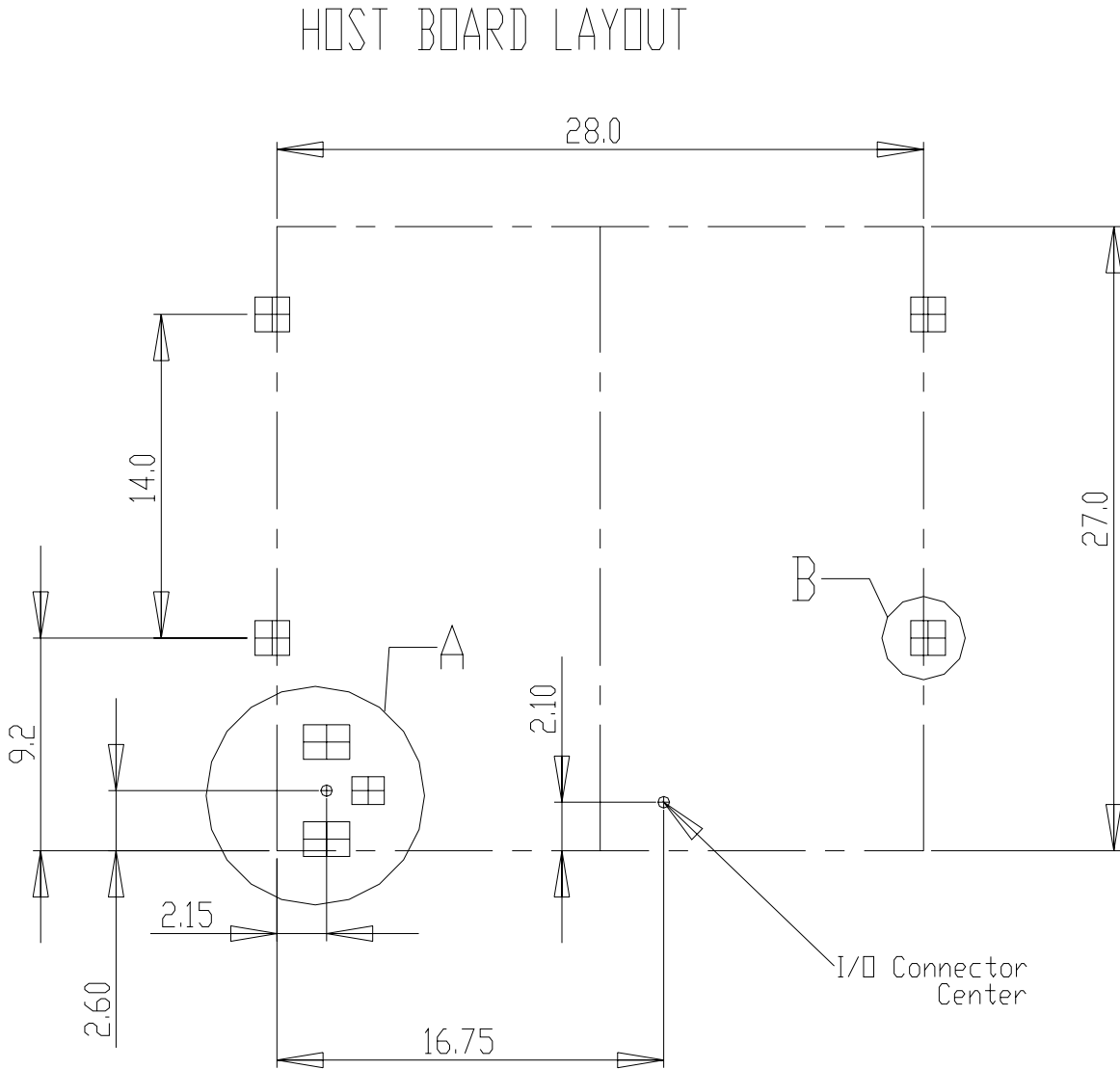
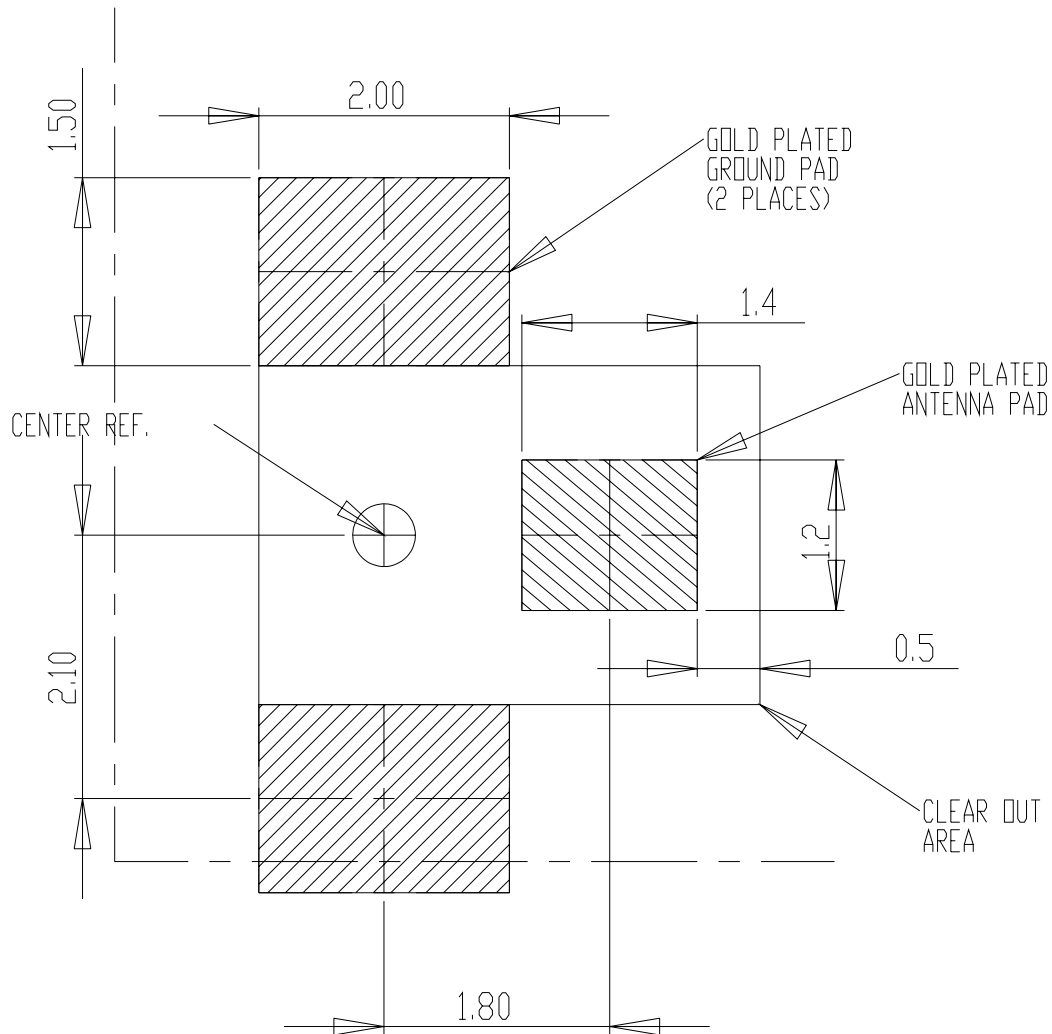

Figure 12 – Module Mounting

BOARD-TO-BOARD RF PADS ON HOST



DETAIL A
SCALE 15 : 1

Figure 13 - Host Pads for Board-To-Board RF Connector

MODEM MOUNTING PADS (4 PLACES)

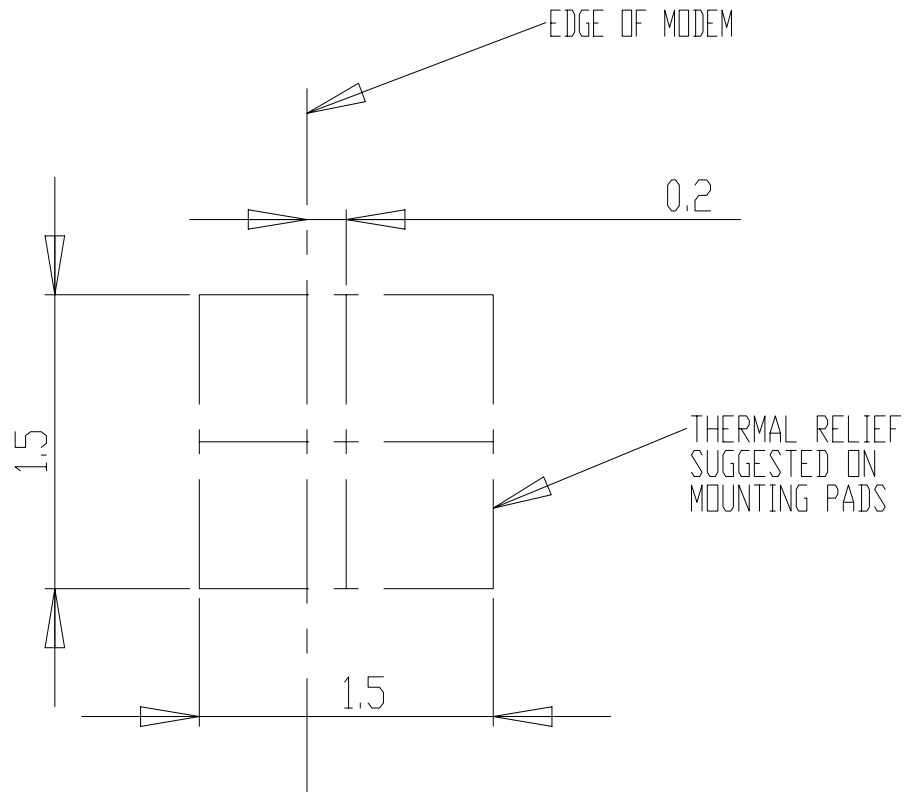

DETAIL B
SCALE 20 : 1

Figure 14 – Modem Mounting Pads

6.2. Connectors

On The Modem: 100-Pin I/O Connector, Plug, SMT, Dual Row, 0.4 mm Pitch

Enfora PN = CON-1040-0100

Molex PN = 55909-1074

On The Host: 100-Pin I/O Connector, Socket, SMT, Dual Row, 0.4 mm Pitch (Mate to module)

Enfora PN = CON-1040-0101

Molex PN = 51338-1074

The mated height of the two connectors is 1.50 mm.

6.3. RF Connection Options

6.3.1. Coaxial Connector Option

On The Modem:

Sunridge MCD Series – Ultimate Miniature Coaxial Interconnect, 1.55mm Mated Height
Contact Sunridge for mating cable options:

Enfora PN = CON-0009-0005

Sunridge PN = MCD-ST-00T

<http://sunridgecorp.com/>

Sunridge Corporation
2500 E. Foothill Blvd. Suite 107
Pasadena, CA 91107
U. S. A.
Tel: (626) 535-1780
Fax: (626) 535-1788

6.3.2. RF Board-to-Board Connector Option

On The Modem:

Enfora PN = CON-0009-0006

Sunridge PN = MCE-15A-G01

On The Host PCB:

No connector required. See Figure for layout details.

6.3.3. I/O Connector Pin Assignments

The following table shows the pin assignments for the input/output connector.

Table 2 - Enabler IIIG Pin Assignments

Pin #	Serial Pin	I/O	Enabler IIIG	Description/Comments (Default Function / Secondary Function)
1		P	VBUS	USB power – Tie to ground if USB not used
2		R	GND	System Ground
3		P	VBUS	USB power – Tie to ground if USB not used
4		R	GND	System Ground
5		I/O	USB_DP/RXD/ MIC_R	5 V tolerant data plus pin in USB modes
6		I	LED_B	LED B sink
7		I/O	USB_DM	5 V tolerant data minus pin in USB modes
8		I	RESERVED	RESERVED
9		I	ID_USB	USB connector identification
10		O	RESERVED	RESERVED
11	7	I	UART_RTS	Request to send
12		I	MCSI_RX/GPIO12	GPIO12 / MCSI Serial data input
13	8	O	UART_CTS	Clear to send
14		I/O	MCSI_CLK/GPIO9	Gpio9 / MCSI Serial Clock I/O
15	2	O	UART_RXD	Serial Data Output
16		I/O	MCSI_FSYNC/GPIO10	GPIO10 / MCSI Frame Synchronization I/O
17	4	I	UART_DTR	Data Terminal Ready
18		O	MCSI_TX / GPIO11	GPIO11 / MCSI Serial Data Output
19	1	O	UART_DCD	Data carrier detect
20		O	GPIO18	GPIO18
21	3	I	UART_TXD	Serial data input
22		I/O	GPIO15	GPIO15
23	9	O	UART_RING	Ring Indicate
24		O	GPIO16	GPIO16
25	6	O	UART_DTR	Data Terminal Ready
26		I/O	GPIO14	GPIO14
27		O	RESERVED	RESERVED
28		O	GPIO17	GPIO17
29		O	RESERVED	RESERVED
30		I/O	GPIO13	GPIO13
31		O	RESERVED	RESERVED
32		O	GPIO20	GPIO20
33		O	RESERVED	RESERVED
34		I	GPIO19	GPIO19
35		I	PWR_CTL	External switch-on event (ON Button) with 32-kHz de-bouncing
36		I	RESERVED	RESERVED
37		I	RESET	External RESET input
38		I	RESERVED	RESERVED
39		I	UART_DBG_RX	Debug UART Serial data input
40		I	RESERVED	RESERVED
41		O	UART_DBG_TX	Debug UART Serial data output
42			RESERVED	RESERVED
43			RESERVED	RESERVED
44			RESERVED	RESERVED
45			RESERVED	RESERVED
46			RESERVED	RESERVED
47		I	HST_DET	Headset Detect (if not used, can be left floating)
48		O	RESERVED	RESERVED
49		I	RESERVED	RESERVED
50			RESERVED	RESERVED

Pin #	Serial Pin	I/O	Enabler IIIG	Description/Comments (Default Function / Secondary Function)
51			RESERVED	RESERVED
52		O	CLK13M_BUF	13 MHz clock Output via 1 kΩ Series Resistor
53		O	HSMICBIAS	Headset microphone bias
54		R	GND	System ground
55		I	HSMIC	Microphone input (Headset)
56		O	CLK32K_BUF	32.768 kHz out, only buffered by 10 kΩ resistor
57		O	HSOL	32 kΩ headset amplifier Left
58		I/O	GPIO_4	GPIO 4
59		O	HSOR	32 kΩ headset amplifier Right
60		I/O	GPIO_3	GPIO 3
61		O	HSOVMID	Headset output common mode
62		I/O	USB_BOOT/ GPIO_2	GPIO 2
63		O	MICBIAS	Microphone bias
64		I/O	GPIO_1	GPIO 1
65		I	MICIP	Microphone amplifier positive input (Handset)
66		I/O	GPIO_7	GPIO 7
67		I	MICIN	Microphone amplifier negative input (Handset)
68		I/O	GPIO_5	GPIO 5
69		R	GND	System Ground
70		I/O	GPIO_6	GPIO 6
71		O	EARP	33 Ω or 120 Ω speaker amplifier (+) (Analog)
72		I/O	GPIO_8	GPIO 8
73		O	EARN	33 Ω or 120 Ω speaker amplifier (-) (Analog)
74		I	ADCIN4	10-bit A-to-D
75		R	GND	System Ground
76		PWR	VRSIM	Output voltage for SIM 1.8 V / 2.85 V (No Connect if onboard SIM holder is used)
77		PWR	VRIO	1.8 V out – Reference for external level translation
78		O	SIM_CLK	SIM Card Reference clock (No Connect if onboard SIM holder is used)
79			RESERVED	RESERVED
80		O	SIM_RST	SIM Card Reference clock (No Connect if onboard SIM holder is used)
81			RESERVED	RESERVED
82		I/O	SIM_IO	SIM Card I/O Data (No Connect if onboard SIM holder is used)
83		I	VBACKUP	Backup Battery Voltage
84		I	SIMDTC	SIM card insertion/extraction detect with 32-kHz debouncing. (If not used, tie to ground.) (No Connect if onboard SIM holder is used)
85		P	VBAT	Power from Host
86		R	GND	System Ground
87		P	VBAT	Power from Host
88		R	GND	System Ground
89		P	VBAT	Power from Host
90		R	GND	System Ground
91		P	VBAT	Power from Host
92		R	GND	System Ground
93		P	VBAT	Power from Host
94		R	GND	System Ground
95		P	VBAT	Power from Host
96		R	GND	System Ground
97		P	VBAT	Power from Host
98		R	GND	System Ground
99		P	VBAT	Power from Host
100		R	GND	System Ground

6.4. Circuit Protection

Other than very low level ESD protection within the module's integrated circuits, the module does not have any protection against ESD events or other excursions that exceed the specified operating parameters.

Generally, ESD protection (typically TVS/Transzorb devices) should be added to all signals that leave the host board. This includes V_{BAT}/V_{CC} .

Series resistors (typically 47 Ω) can also be added in series with data lines to limit the peak current during a voltage excursion.

NOTE: DO NOT ADD SERIES RESISTANCE TO THE SIM ELECTRICAL LINES.

Minimum ESD Protection Levels		ESD/Input Voltage			
Pin #'s	ESD Test Method	Min	Nom/ Avg	High/ Peak	Units
Pins 11 – 24, 26-34, 36, 38, 40, 42, 48, 50, 52, 58, 60, 62, 64, 66,68, 70, 72, 78, 80, 82	Human Body Model EIA/JEDEC22-A114-A	500			V
	Charge Device Model EIA/JEDEC22-C101-A	200			V
Pins (all VBUS/PWR), 5 – 10, 35, 37, 47, 49, 51, 52, 53, 55 – 57, 59, 61, 63, 65, 67	Human Body Model EIA/JEDEC22- A114-A	2000			V
	Charge Device Model EIA/JEDEC22- C101-A	500			V
RF Antenna	IEC 61000-4-2			8000	V



Caution – It is the Integrator's responsibility to protect the Enabler IIIG module from electrical disturbances and excursions, which exceed the specified operating parameters.

6.5. Antenna

The GSM0308-xx module has one RF antenna connection on the module. The connection is for the GSM section of the module.

6.6. Control Connector Signal Descriptions and Functions



Please note that the following descriptions are intended to provide hardware-level definitions. In some cases, specific lines will have no firmware functionality implemented. Information for each hardware-specific feature will be noted in the appropriate section.

6.6.1. Module Power (Pins 85, 87, 89, 91, 93, 95, 97, 99)

The Enfora Enabler IIIG module uses a single voltage source of VCC=+3.3V to 4.5V. (The exact values of the uplink currents are shown in the tables in section 5.3.1.)

V _{BAT}	Parameter/Conditions	Min	Typ	Max	Units
Main Battery Supply	Voltage In Regulation	3.3		4.5	Vdc
Peak Current	1000 μ F on Host at Module Connector				mA



The uplink burst will cause strong ripple on the voltage lines and should be effectively filtered. It is recommended that 1000 to 2000 μ F of capacitance be placed as close to the modem I/O connector as possible.

It should be noted that the input voltage level should not drop below the minimum voltage rating under any circumstances, especially during the uplink burst period.

6.6.2. Reset Signal (Pin 37)

The Reset signal is used to force the modem to start at a known state. When the Reset is pulled low the modem will immediately suspend any function and will not exit the reset state until the Reset signal is released to be pulled high. Once the transition from low to high is complete, the modem will boot. The Reset signal is falling edge triggered, so the reset function is set immediately when the signal is pulled low.

When using Reset, it will immediately detach the connection from the GSM network, this is not considered ideal. Typically during a normal shutdown, the modem will issue a detach request to the network to indicate that it is being removed. Reset must not be used to 'power off' the device, but only as a last resort when there is no response from the module.

Controlling the Reset signal must only be preformed by an open collector/open drain device. Driving the Reset signal high will interfere with the normal operation of the modem power on/off sequences. Power sequencing cannot be guaranteed if Reset is being driven high by an external device. If driving from an external microprocessor, the reset can be controlled by driving the control pin low as an output, then change the pin control to be an input, this will satisfy the high impedance requirement.

The Reset pin can also be monitored as a system on/off indication. When the modem is powered on and in a normal operating state, this pin will be set high. When the modem is powered down or in the 'off' state, this pin will be low. Any monitoring circuit **MUST** be high impedance, such as a logic gate or micro-processor input.

Parameter	Parameter/Conditions	MIN	TYP	MAX	UNIT
V _{IL}	Input Voltage – Low or float			0.58	Vdc
V _{IH}	Input Voltage – High	1.36		1.95	Vdc
I _{PU}	Internal Pull-Up Resistor	-40	-31	-15	μA
I _{IL}	Current sink			-2.0	mA
Reset Pulse Duration		10			mS

6.6.3. Power Control (Pin 35) (PWR_CTL)

The input is equivalent to a “phone ON-button”. A falling-edge on this Active-Low input will switch-ON the module or switch-OFF the module after a delay*. This input has a “weak pull-up” resistor internal to the module. This input can be left grounded if the “RTC Sleep Function” is not required. If RTC Sleep is required, then the PWR_CTL line must be floated to allow the internal resistor to pull the line high. See section 6.6.9 for more info on the RTC.

Controlling the Power Control signal must only be performed by an open collector/open drain device. Driving the Power Control signal high may interfere with the normal operation of the modem. If driving from an external microprocessor, the Power Control can be controlled by driving the control pin low as an output, then change the microprocessor’s pin control to be an input (this will satisfy the high impedance requirement).

***The OFF Delay is controlled by the AT\$OFFDLY command. A value of 0 disables the PWR_CTL line from turning the module off. 0 is the default value.**



To enable the module to switch-OFF via PWR_CTL you must set AT\$OFFDLY to a value other than 0. The valid range is 100 to 1000 milliseconds.

6.6.3.1. Turning ON the Enabler IIIG

Pulling the PWR_CTL line on the Enabler IIIG LOW for at least 50mS (after Vbat is applied and stabilized) is required to turn it ON. Section 6.6.3.3 describes various ways to provide the signal.

Do not use a pull-up resistor on the PWR_CTL line since the line is pulled up internal to the modem.

6.6.3.2. Turning OFF the Enabler IIIG

The Enabler IIIG can be turned off by either a low pulse on the PWR_CTL line, or by a software command (AT\$OFF, see AT guide for further details). Section 6.6.3.3 describes various ways to provide the signal.

6.6.3.3. Using the Power Control Signal

Typical use powering module on/off with a switch:

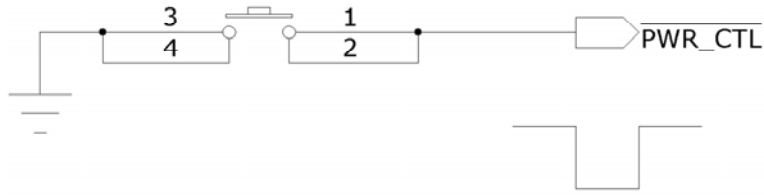
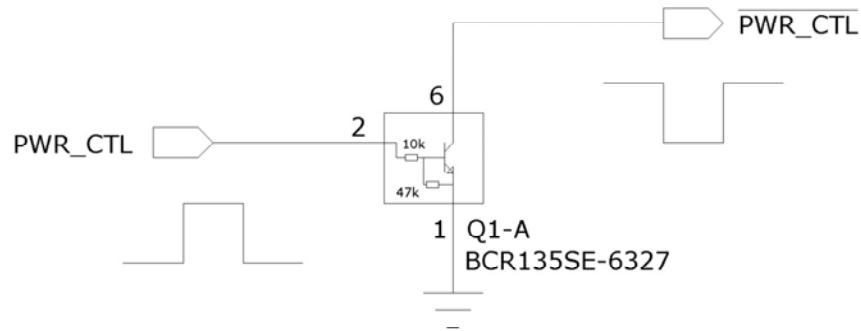

Figure 15 – Power Control Switch

Typical use controlling PWR_CTL from microcontroller:



Typical connection of PWR_CTL to modem:

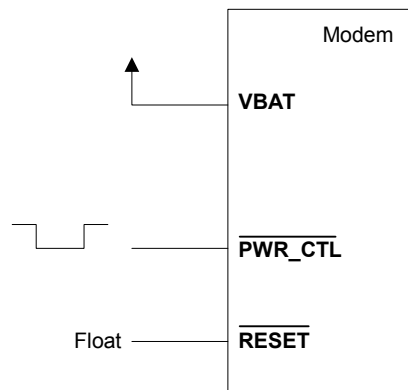

Figure 16 - External Power Control Signal (no external processor) shows a typical connection to the Enfora Enabler IIIG module in a machine-to-machine application using the external **PWR_CTL** signal, when there is not an external processor controlling the power on/off states. The RTC deep sleep functions will **NOT** function since the **PWR_CTL** pin is tied low, the processor will never stay in a “RTC Sleep” mode. To reset the module, either the **RESET** pin is toggled as described in the ‘Reset Signal’ section, or power (**VBAT**) must be cycled.

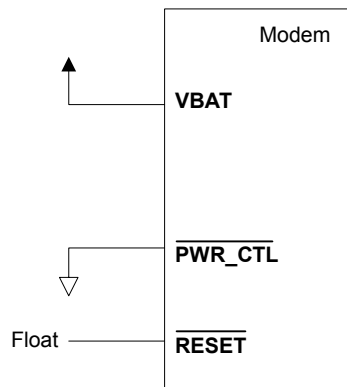

Figure 16 - External Power Control Signal (no external processor)

Figure 17 - Power Control Signal (using external processor) shows a typical connection from an external processor to the Enfora Enabler IIIG module, using the external PWR_CTL signal. The Enfora Enabler IIIG can be powered on by using the PWR_CTL signal, and reset with the RESET signal. When using PWR_CTL, the I/O or serial lines can be at any voltage state desired. It is recommended that the I/O and serial lines be tri-stated or set low when the GSM0308 is shutdown for an extended period of time to prevent any leakage current from the processor to the modem.

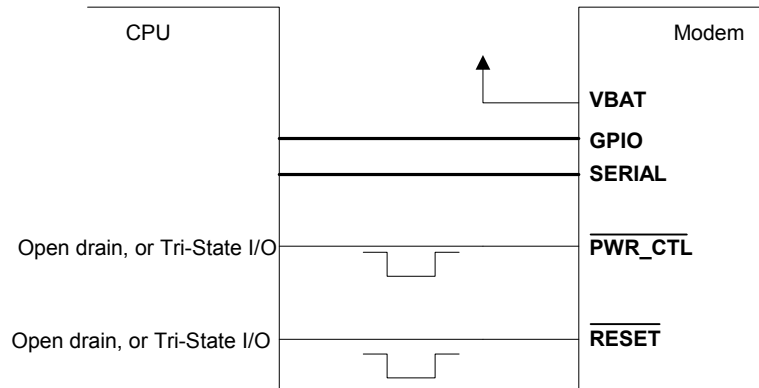

Figure 17 - Power Control Signal (using external processor)

Parameter	Parameter/Conditions	MIN	TYP	MAX	UNIT
V _{IL}	Input Voltage – Low or float			0.3 x V _{BAT}	Vdc
V _{IH}	Input Voltage – High	0.7 x V _{BAT}		1.95	Vdc
I _{PU}	Internal Pull-Up Resistor	-40	-31	-15	μA
I _{IL}	Current sink			-2.0	mA
ON Pulse Duration		10	50		mS
OFF Pulse Duration	Minimum is programmable (AT\$OFFDLY)	10	100	5000	mS
Boot time	Time to boot from power on to command prompt		1.1		Sec

6.6.4. Level Translation Reference Power (Pin 77)

To be used as a voltage reference source ONLY. Do not connect current loads to this pin. This pin must be decoupled to ground with at least a 0.1 μ F capacitor at the output. Noise induced on this pin will affect the performance of the baseband.

Low Power Mode is entered when RTCWAKE is used to power down the modem with just the RTC running.

V _R I/O	Parameter/Conditions	Min	Typ	Max	Units
Output voltage V _{OUT}	ON mode	1.65	1.8	1.95	Vdc
	LOW POWER mode	1.65	1.8	1.95	
Rated output current I _{OUT}	ON mode			20	mA
	LOW POWER mode			0.5	

6.6.5. USB (Pins 1, 3, 5, 7, 9)

This is for Enfora Debug only

Pin Name	Pin Number	Signal Direction	Description
USB_VBUS	1, 3	In	5 V tolerant power Supply VBUS line; Used only as a USB sense, not for powering the module. (optional connection)
USB_DP	5	Analog I/O	5 V tolerant data plus pin in USB
USB_DM	7	Analog I/O	5 V tolerant data minus pin in USB
ID_USB	9	Analog I/O	5 V tolerant ID line, it defines the type of device connected to the phone's USB port; And also the default state (host / device) at the cable connection; The transceiver senses the voltage of this pin to determine if the pin is either floating (typical), grounded or resistively connected to ground (102 k Ω , 200 k Ω , 440 k Ω);

5V Tolerant Transceiver

USB	Parameter/Conditions	Min	Typ	Max	Units
Input Voltage		4.4	4.65	5.25	V
Output voltage	High (Driven)	2.8	3.3	3.6	Vdc
	Low	0.0	0.1	0.3	Vdc
Transceiver D+/- Leakage Current		-2		2	μA

6.6.6. General Purpose Input/Output Interface

GPIO number	Pin number	Secondary Function
GPIO 1	64	
GPIO 2	62	
GPIO 3	60	
GPIO 4	58	
GPIO 5	68	
GPIO 6	70	
GPIO 7	66	
GPIO 8	72	
GPIO 9	14	MCSI_CLK
GPIO 10	16	MCSI_FSYNC
GPIO 11	18	MCSI_TX
GPIO 12	12	MCSI_RX
GPIO 13	30	
GPIO 14	26	
GPIO 15	22	
GPIO 16	24	
GPIO 17	28	
GPIO 18	20	
GPIO 19	34	
GPIO 20	32	

Each general-purpose signal may be selected as inputs or outputs. The GPIOs can be used independently as a user-specified function, or may be used to provide modem control and status signals. Several examples of modem control signals are: power shutdown command, register/deregister on network command, and transmitter disable. Several examples of modem status signals are: registration status and ready-for-power-down status to be used with power shutdown command signal.

I/O Lines	Parameter/Conditions	Min	Typ	Max	Units
V_{IL}	Input Voltage – Low	0		0.60	Vdc
V_{IH}	Input Voltage – High	1.11		1.8	Vdc
V_{OL}	Output Voltage – Low			0.45	Vdc
V_{OH}	Output Voltage – High	1.26			Vdc
I_{OL} / I_{OH}	Rated Output Current			4	mA

The below table shows the factory default modem GPIO configuration:

I/O No	PU/PD Enabled	PU/DN	I/O setting	PU/PD capability	PU Value KOhm	PD Value KOhm	Iout	Notes
1	1	PU	IN	PU/PD	18	90	4	
2	X	X	IN		-	-	8	10k Pulldown on Modem
3	1	PD	IN	PD	-	18	8	
4	1	PU	IN	PU/PD	-	90	4	
5	1	PU	IN	PU/PD	-	90	8	
6	1	PU	IN	PU/PD	-	90	4	
7	1	PU	IN	PU/PD	-	90	4	
8	1	PU	IN	PU/PD	-	90	8	
9	1	PU	IN	PU	18	-	8	
10	1	PU	IN	PU	18	-	8	
11	1	PU	IN	PU	18	-	8	
12	1	PU	IN	PU	18	-	8	
13	1	PD	IN	PD	-	18	8	
14	1	PD	IN	PD	-	18	8	
15	1	PD	IN	PD	-	18	8	
16	1	PU	IN	PU/PD	90	90	8	
17	1	PU	IN	PU/PD	90	90	8	
18	1	PU	IN	PU	18	-	8	
19	1	PU	IN	PU/PD	18	90	8	
20	1	PU	IN	PU/PD	90	90	8	

Factory Default Settings for I/O Pins, PU/PD Capability and Value of PU/PD Resistors.

6.6.7. RTC Sleep

In this mode, the modem is off except for its Real-Time-Clock. When put into this mode, the modem can wake itself up at a designated time/interval. See Section 4.10 of the Enabler III AT command manual for details

6.6.8. Serial Interfaces & Handshake (Pins 11, 13, 15, 17, 19, 21, 23, 25)

The pin naming for TX/RX/RTS/CTS/DTR/DSR is referenced as a DTE. The DTE device should match their input pins to the Enfora outputs and visa-versa. Additionally, there are AT commands that may need to be executed in order to insure proper operation. See the chart below.

9 way D Connector Pin Number	Signal	Signal Direction	Enfora Pin Number	Enfora AT Command
1	Carrier Detect (CD)	from DCE	19	AT&C
2	Receive Data (RD)	from DCE	15	
3	Transmit Data (TD)	from DTE	21	
4	Data Terminal Ready (DTR)	from DTE	17	AT&D
5	Signal Ground	both		
6	Data Set Ready (DSR)	from DCE	25	
7	Request To Send (RTS)	from DTE	11	AT+IFC
8	Clear To Send (CTS)	from DCE	13	AT+IFC
9	Ring Indicator (RI)	from DCE	23	

The key features of the UART in the modem mode are as follows:

- 16C750 compatibility
- Baud rate from 300 bits/s up to 115200 Kbits/s, autobaud
- Configurable data format:
 - Data bit: 5, 6, 7, or 8 bits
 - Parity bit: even, odd, none
 - Stop bit: 1, 1.5, 2 bit(s)
- Hardware flow control RTS/CTS
- Software flow control using XON/XOFF characters

The Enabler IIIG module is designed to be used like a DTE device.

Default settings are 8 data, 1 stop, no parity, and autobaud. DTR may be used to force the modem into AT command mode from online data mode (See AT Command Document, command AT&D). RTS and CTS may be used for hardware handshaking. DSR is always active (connected to ground) while the modem is on. RING may be used to alert the host to a variety of incoming calls.

For a minimal implementation, connect RxData and TxData to the COM port serial data lines, connect DTR (pin 17) and RTS (pin 11) to GND.

6.6.8.1. Ring Indicate (Pin 23)

The Enabler IIIG module is capable of using the Ring line to discern the type of incoming call. The indicator can be monitored via a hardware line available on the 100-pin I/O signal connector.

The function of the Ring line depends on the type of the call received.

When the module is receiving a *voice call*, the Ring line goes low for 1 second and high for another 2 seconds. Every 3 seconds the ring string is generated and sent over the Receive

(Data Out) (Rx) line. If there is a call in progress and call waiting is activated for a connected handset or hands free device, the Ring pin switches to ground in order to generate acoustic signals that indicate the waiting call.

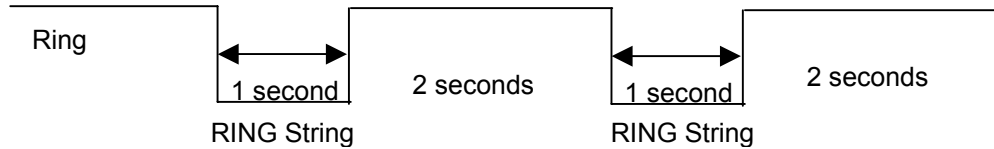

When a *Fax* or *data call* is received, Ring goes low and will remain low. Every 3 seconds a ring string is generated and sent over the Receive (Data Out) (Rx) line.

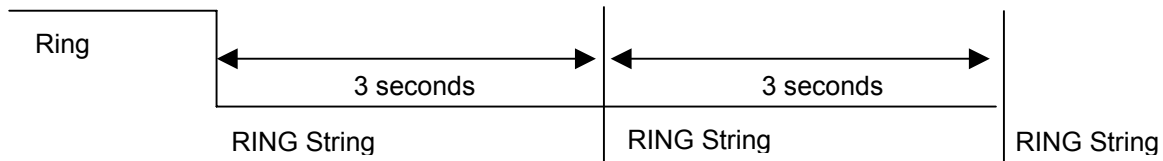

When an incoming SMS is received, Ring indicate goes low for 1 second, then returns to a high state. See below logic diagram.

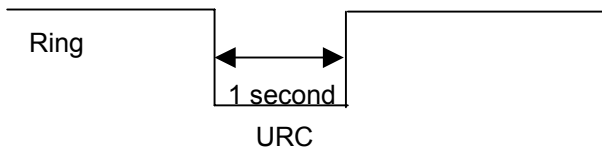

Figure 18 - Ring Indicate Timing

Serial I/O & Control	Parameter/Conditions	Min	Typ	Max	Units
V _{IL}	Input Voltage – Low			0.54	Vdc
V _{IH}	Input Voltage – High	1.26		1.95	Vdc
V _{OL}	Output Voltage – Low			0.54	Vdc
V _{OH}	Output Voltage – High	1.26		1.95	Vdc
I _{OL} / I _{OH}	Rated Output Current			2.0	mA

6.6.9. MCSI – Multi-Channel Serial Interface (Pins 12, 14, 16, 18)

This port is only available in Master mode and to be used for PCM digital audio. Below are the settings for configuring it operation and the interface specification:

Digital Audio Configuration

The default settings for the digital audio are:

Mode = Master
MCSI_CLK = 520KHz
Word Size = 16 Bits
Sync Pulse = 8KHz
Frame mode = burst
Clock edge Sync = rising edge

Configuring the MCSI for Digital Audio

The following two commands are required to set the unit up in digital audio mode:

```
AT$voicepth=2
```

This configures the EIII module to use digital audio instead of analog audio.

```
at$ioblk=0,1
```

This configures the I/O pins of the module to be used as the secondary function which is the MCSI port. It automatically configures the direction of the pins.

Do not alter the settings for these 4 pins manually (direction, pull up or alternate configuration) as this will stop the MCSI port working for digital audio.

Data Format

The 16 bit word is sent MSB first. Data received is also MSB first. No other data manipulation is done within the module.

Pin Name	Pin Number	Signal Direction	Description
MCSI_RX	12	I	Serial Data Input
MCSI_TX	18	O	Serial Data Output
MCSI_CLK	14	IO	Serial Clock I/O
MCSI_FSYNC	16	IO	Frame Synchronization I/O

6.6.10. VBACKUP Input (Pin 83)

The backup battery can be recharged from the main battery. A programmable voltage regulator powered by the main battery allows recharging the backup battery. The backup battery charge starts when the following conditions are met:

Backup battery charge is enabled by a control bit:

- Main Battery voltage > Backup Battery voltage
- Main battery > 2.8 Vdc

Note: If the backup battery is not present, the backup battery pin is connected to main battery pin V_{BACKUP} is a power input for the Real-Time-Clock when using RTC-Sleep Function (Section 6.6.7)

V_{BACKUP}	Parameter/Conditions	Min	Typ	Max	Units
Input Voltage Range	ON mode	2.5	V_{CC1}	5.5	Vdc
	BACKUP mode, $V_{BAT}=0v$	1.9	V_{BACKUP}	5.5	
	BACKUP mode, $V_{BACKUP}=0v$	1.9	V_{CC2}	3.0	
Input Current				10	μA

6.6.11. Using VBACKUP

V_{BACKUP} is a backup voltage that can maintain the RTC clock and alarm functions. If V_{BACKUP} is not present in the system (intentionally or not) the RTC clock may still be powered if leakage voltage exists on VCC. Otherwise, the RTC clock will lose power and be reset when VCC is restored.

PARAMETER	Parameter/Conditions	Min	Typ	Max	Units
Backup Voltage (Real-Time-Clock)					
V_{BACKUP}	Backup Voltage for Real-Time-Clock	2.7	3.0	4.5	Vdc
I_{BACKUP}	Input Current ($V_{BACKUP} = 3.2 V$, $V_{BAT} = 0 V$, No Load on GPIO or Serial Port)		3.0	6.0	μA

V_{BACKUP} had been tested in the above scenarios and does not contribute to leakage. It will properly provide backup power to the RTC clock.

6.6.12. 32 kHz output (Pin 56)

A 32.768 kHz signal is available as an output from the module. This signal should only be used as an input to a high impedance device. Additional loads or capacitance on the line may cause performance issues with the module. If the line is not used, leave floating.

32kHz Clock-Out	Parameter/Conditions	Min	Typ	Max	Units
V_{IH}					Vdc
V_{IL}					Vdc
Maximum capacitor load				tbd	pF
Maximum resistive load					Ω
Frequency	± 30 ppm		32.768		kHz

6.6.13. 13 MHz output (Pin 52)

A 13 MHz signal is available as an output from the module. This signal should only be used as an input to a high impedance device. Additional loads or capacitance on the line may cause performance issues with the module. If the line is not used, leave floating.

13 MHz Clock-Out	Parameter/Conditions	Min	Typ	Max	Units
V_{IH}		TBD			Vdc
V_{IL}				0.3	Vdc
Maximum capacitor load				TBD	pF
Maximum resistive load				TBD	Ω
Frequency	± 0.1 ppm when registered on GSM network; ± 12 ppm typical when not registered;		13.000		MHz

6.6.14. Analog-To-Digital Input (Pin 74)

The monitoring ADC (MADC) consists of a successive approximation 10-bit analog-to-digital converter (ADC).

Analog-To-Digital Input	Parameter/Conditions	Min	Typ	Max	Units
ADC_{BRES}	ADC Binary Resolution			10	Bits
ADC_{REF}	ADC Reference Voltage		1.75		Vdc
V_{ADC}	ADC Range	0		1.75	Vdc
Integral/Differential Non-Linearity		-2		2	LSB
Input Leakage			tbd		μA
Retuning Frequency			1		MHz

6.6.15. Handset Microphone Input (Pins 65, 67)

The handset differential inputs MICIP and MICIN can be amplified by the differential handset microphone amplifier. This amplifier has a gain of 25.6 dB and a bias generator MICBIAS provides an external voltage of 2 V or 2.5 V to bias the microphone.

Handset Mic Input	Parameter/Conditions	Min	Typ	Max	Units
Maximum Input Range – Mic(+) to Mic(-)	Inputs 3 dBm0 (Max. digital sample amplitude when PGA gain set to 0 dB)			32.5	mV _{RMS}
Nominal Ref. Level – Mic(+) to Mic(-)	Differential MIC		-10		dBm0
Differential Input Resistance – Mic(+) to Mic(-)	Differential MIC, <i>MICAMP</i> gain = 25.6 dB (INMODE = 0001)		36		k Ω
Microphone Pre-Amplifier Gain	Differential MIC		25.6		dB

6.6.16. Handset Microphone Bias Output (Pin 63)

Mic Bias Output	Parameter/Conditions	Min	Typ	Max	Units
Bias Voltage on Mic(+)	Set to 2.0 V	1.9		2.1	Vdc
	Set to 2.5 V	2.4		2.6	Vdc
Mic Bias Current Capability				2.0	mA

6.6.17. Handset Speaker Output (Pins 71, 73)

Pin Name	Pin Number	Signal Direction	Description
EARP	71	O	Earphone positive output
EARN	73	O	Earphone negative output

The earphone amplifier provides a full differential signal on the terminals EARP and EARN (Earphone).

Handset Spkr Output	Parameter/Conditions	Min	Typ	Max	Units
Maximum Differential Resistive Load	Output Swing 3.9 V _{PP}		120		Ω
	Output Swing 1.5 V _{PP}		33		Ω
Maximum Differential Capacitive Load				100	pF
Common Mode Minimum Resistive Load	At Internal Speaker (+) or (-)		200		kΩ
Common Mode Maximum Capacitive Load	At Internal Speaker (+) or (-)			50	pF
Amplifier Gain	EARG = 1		1		DB
	EARG = 0		-11		dB

Parameter	Test Conditions	Min	Typ	Max	Units
Earphone output swing at EARP-EARN	Distortion ≤ 2% and 120 Ω, VSP input level = +3 dBm0, amp gain = -11 dB		0.98		V _{P-P}
	Distortion ≤ 2% and 33 Ω, VSP input level = -5.34 dBm0, amp gain = -11 dB		0.38		
	Distortion ≤ 2% and 120 Ω, I2S input level = +3 dBm0, amp gain = -11 dB		0.93		
	Distortion ≤ 2% and 120 Ω, VSP input level = +3 dBm0, amp gain = 1 dB	3.1	3.92		
	Distortion ≤ 2% and 33 Ω, VSP input level = -5.34 dBm0, amp gain = 1 dB	1.2	1.5		
	Distortion ≤ 2% and 120 Ω, I2S input level = +3 dBm0, amp gain = 1 dB	2.96	3.7		
Earphone amplifier gain	EARG = 1		1		dB
	EARG = 0		-11		dB
Earphone amplifier state in power down			High Z		
Earphone amplifier power supply rejection	1 kHz, 100 mVp-p		50		dB

An external audio amplifier should be used for loads of less than 16 Ω or if volume is inadequate.

6.6.18. Headset Microphone Input (Pin 55)

Mic Input	Parameter/Conditions	Min	Typ	Max	Units
The headset differential inputs HSMIC and AUXI can be amplified by the differential handset microphone amplifier. This amplifier has two different gains 4.9 dB or 25.6 dB and a bias generator HSMICBIAS provides an external voltage of 2 V or 2.5 V to bias the microphone. Headset Mic Input					
Maximum Input Range	Inputs 3 dBm0 (Maximum digital sample amplitude with PGA gain set to 0 dB), <i>AUXAMP</i> gain = 18 dB, Single HSMIC			78	mV _{RMS}
Nominal Ref. Level			-10		dBm0
Microphone Pre-Amplifier Gain				18	dB
Input resistance at HSMIC	HSMIC single input, <i>AUXAMP</i> gain = 18 dB		40.5		kΩ

6.6.19. Headset Microphone Bias Output (Pin 53)

Mic Bias Output	Parameter/Conditions	Min	Typ	Max	Units
Bias Voltage on Mic(+)	Set to 2.0 V	1.9		2.1	Vdc
	Set to 2.5 V	2.4		2.6	Vdc
Mic Bias Current Capability				2.0	mA

6.6.20. Headset Speaker Output Left & Right (Pins 57, 59)

Pin Name	Pin Number	Signal Direction	Description
HSOL	57	O	Headset Out 32Ω Speaker Left
HSOR	59	O	Headset Out 32Ω Speaker Right
HSOVMID	61	I	Headset Out pseudo ground return

The left and right headset amplifiers provide the stereo signal on terminals HSOL and HSOR. A pseudo ground is provided on terminal HSOVMID to eliminate external capacitors. The mono audio signal can be provided on the Right or the Right and Left headset outputs. HSOVMID is available to allow integrators to supply a bias or DC offset to increase the dynamic range of the Headset.

Headset Spkr Output	Parameter/Conditions	Min	Typ	Max	Units
Maximum Swing	Distortion \leq 2% and 32 Ω , VSP input level = +3 dBm0	1.6	1.96		V _{P-P}
	Distortion \leq 2% and 32 Ω , I ² S input level = +3 dBm0	1.48	1.85		
Maximum Capacitive Load				100	pF
Minimum resistive load at HSOL and HSOR: Zload			32		Ω
Amplifier Gain			-5		dB
HSOL/R amplifier Power supply rejection	1 kHz, 100 mVpp		50		dB
Amplifier State in Power Down			High Z		

The left and right channels of the headset speaker output are a single ended output. An external audio amplifier should be used for loads of less than 32 Ω or if volume is inadequate.

6.6.21. Headset Output Common Mode (Pin 61)

The left and right headset amplifiers provide the stereo signal on terminals HSOL and HSOR. A pseudo ground is provided on terminal HSOVMID to eliminate external capacitors.

HSOVMID	Parameter/Conditions	Min	Typ	Max	Units
Maximum Capacitor Load				200	pF
DC Level		1.2	1.35	1.5	V

6.6.22. Headset Detect (Pin 47)

Headset Plug/Unplug detection. This pin is used to automatically switch to the headset audio path when enabled with AT\$VSELECT=3. The device will default to handset when no Headset is detected.

- 2 modes:
 - Module already ON (Battery connected, VRIO ON) and plug event;
 - Module OFF and plug event: the plug detection will be effective once VRIO is set ON
- Plug and unplug detections are digitally debounced (debouncing time = 8 ms).
- The jack plug detection feature is addressed through the HSDET pin. The integrated pull up, connected to the pin, forces a high level (VBAT) when the headset load is not connected. At jack insertion headset load connection ($32\ \Omega$) imposes a low level on that node (Headset left channel): as an example HSDET = 1 mV after jack plug for VBAT = 4 V.
- Input comparator threshold voltages are defined as $V_{Tlow} = V_{BAT}/2 - 100\text{ mV}$ and $V_{Thigh} = V_{BAT}/2 + 100\text{ mV}$, $V_{BATmin} = 3.2\text{ V}$. The plug and unplug detection remains functional if there is no signal from HSOL amplifier output (stereo path is OFF) or if there is a signal from HSOL (stereo path is ON): maximum level on HSOL when the stereo path is ON is 1 Vp-p which stays far enough from the comparator threshold levels $V_{BATmin}/2 - 100\text{ mV}$ and $V_{BATmin}/2 + 100\text{ mV}$.
- Jack plug detection is functional if a plug event occurs before the power up of the module or if the plug event occurs after the power up of the module: analog detection part is always active if the battery is connected. Detection interrupts will be generated once the VRIO regulator is power up during the module power up sequence.
- A level change on HSDET pin is sensed by a Schmitt trigger to provide a jack detection signal to the audio digital control. The audio digital control receives the detection signal and proceeds to a digital debouncing (time: $8\text{ ms} = 256 * 32\text{ kHz}$ clock periods) before sensing that a plug event happened on the jack connector.

Headset Detect	Parameter/Conditions	MIN	TYP	MAX	UNIT
Low level input voltage VIL related to VBAT				0.3 * VBAT	V
High level input voltage VIH related to VBAT		0.7 * VBAT			V
Current with pull-up		-40	-31	-15	μA

6.7. Subscriber Identity Module (SIM) Carrier (Pins 76, 78, 80, 82, 84)

The SIM, an integral part of any GSM terminal device, is a “smart card” that is programmed with subscriber information:

- The user information consists of an International Mobile Subscriber Identity (IMSI) number, which is registered with the GSM provider, and an encryption Ki (pronounced "key"). This information consists of a microprocessor and memory installed on a plastic card.

Note: The SIM is not provided with the Enfora Enabler IIIG module. The SIM must be obtained from the GSM service provider and must be provisioned by the operator for data and/or voice. Always take care to protect the SIM: the GSM terminal will not operate without the SIM installed.

The SIM provides the IMSI for authentication. To gain access to the GSM network, the network must recognize the IMSI number, and the terminal must be able to properly decrypt the data sent by the network. The SIM also serves as a buffer for SMS messages, storing the message for transmission until a radio link is available and buffering received messages until retrieved.

6.7.1. SIM Integration for the Enfora Enabler IIIG Module

The Enabler IIIG module default configuration does not include an on-board SIM carrier. Enfora provides a separate product SKU for the Enabler IIIG module with the integrated SIM carrier.

6.7.2. Using a Remote SIM with the Enfora Enabler IIIG Module (Pins 76, 78, 80, 82, 84)

The Enabler IIIG module default configuration does not include an on-board SIM carrier.

The module supports the use of 1.8 V and 3 V SIM cards. The module includes a hardware interface module dedicated to Universal Subscriber Identity Module (USIM). All baud-rates defined in ISO 7816-3 standard are supported for high-speed transmission.

The module optionally includes an on-board SIM carrier. All other modules require a remote SIM carrier/connector. If the module is going to be integrated using a remote SIM, the following guidelines are provided:

- To utilize a remote SIM, the integrator must provide a suitable SIM connector.
- The maximum distance from the module to the remote SIM connector must not exceed 25.4 cm (10 inches).
- It is recommended to have Zero resistance between the SIM connector and the module.
- External ESD Protection is Required;
 - 15 kV Air Discharge;
 - 8 kV Contact Discharge;

The transorb must have a low junction capacitance (typically < 10 pf) such as the following part:

Enfora PN: TRS-0000-5009
Manufacturer: On Semi
Manufacturer PN: NSQA6V8AW5T2G

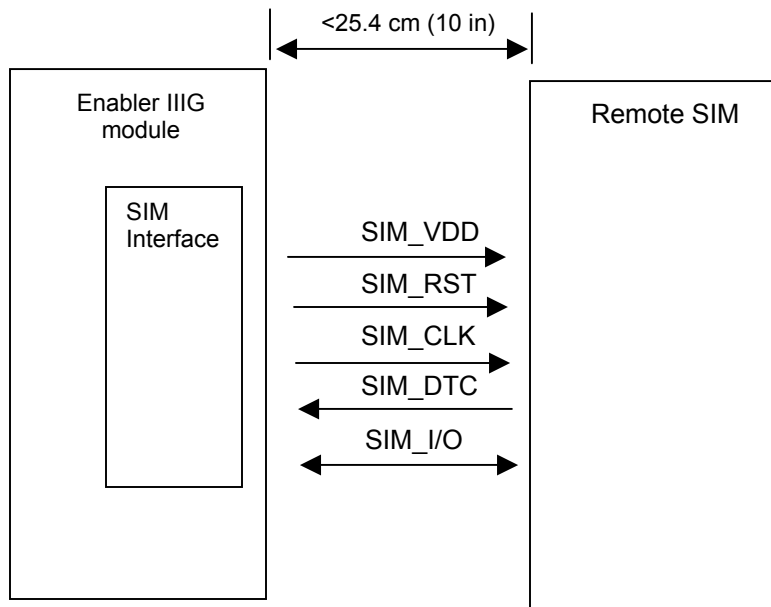

Figure 19 - Remote SIM Interface

Pin Name	Pin Number	Signal Direction	Description
SIM_VDD	76	O	SIM VDD
SIM_CLK	78	O	Card Reference Clock
SIM_RST	80	O	Card Reset
SIM_I/O	82	I/O	Card I/O Data
SIMDTC	84	I	Card detect

The module provides the regulated supply voltage for the SIM-card and the circuitry to detect the insertion or extraction of the SIM-Card in or from the mobile.

The SIMDTC is disabled by default (see AT\$SIMDTC in the EIII AT Command Manual for settings). When enabled, the SIMDTC pin has an internal pull up to Vcc and can be configured to detect a SIM insertion when the SIMDTC is either pulled to ground or left floating.

It can configured to detect either just a SIM removal or both removal and insertion.

When the module detects a SIM removal, it will de-register from the network. When the module is configured to and detects a SIM insertion, it will reset the module and re-register on the network.

The SIM-card presence detection logic is active even when the system is in idle model.

USIM	Parameter/Conditions	Min	Typ	Max	Units
VDD	SIM VDD voltage	1.65	1.8	1.95	V
		2.7	2.85	2.95	V
VIH	High level input voltage	1.15			V
VIL	Low level input voltage			0.61	V
VOH	High level output voltage, IO = 4 mA	Vdd-0.45			V
VOL	Low level output voltage, IO = 1 mA			0.4	V
Ii	Input leakage current			±1	µA
Iout	Output current		4		mA
PU	PU resistance		32		kΩ
PD	PD resistance		30		kΩ
Iz	Leakage current			± 30	µA
Card Detect	Debouncing time (SIM-card insertion)		0.5		mS
	Debouncing time (SIM-card extraction)		15		mS
	Pull-up resistor (resistor + resistive switch)		475		kΩ

6.7.2.1. Remote SIM Component Information

Any compatible SIM carrier can be used in conjunction with the Enabler IIIG module. For example:

Lumberg P/N 8840_A_21.

or Suyin P/N: 254016MA006G103ZL

7. GSM/GPRS Modes of Operation

GSM/GPRS supports many optional services and modes. The Enfora Enabler IIIG module supports the following GSM/GPRS services:

- Circuit-switched data
- Short-Message Services (SMS)
- Class B GPRS Functionality
- Voice communication

7.1. Enabling the Transmission Modes for the GSM/GPRS Services

Each of the GSM/GPRS services has two modes that can be enabled separately:

- Mobile-originated (MO): allows the making of a service request (such as, making a telephone call or sending an SMS)
- Mobile-terminated (MT): allows receiving a service request (such as receiving a telephone call or an SMS)

Note: Contact your local GSM operator to ensure that the services and modes have been provisioned for the SIM.

7.2. Voice Communication

The Enfora Enabler IIIG module has full voice capabilities, provided the necessary connections have been made for the speaker and microphone pins on the 100-pin I/O connector. The Enfora **Enabler-IIIG AT Command Set Reference - GSM0308AT001** has the entire list of commands that can be used to control the voice functionality. The quick start guide in this manual provides a basic command set that can be used to initialize and test the voice functionality.

The Enfora Enabler IIIG module supports four vocoder compression algorithms for voice communication: Full-Rate (FR), Enhanced Full-Rate (EFR), Half-rate (HR) and Adaptive Multi-rate (AMR).

7.3. Circuit-Switched Data

In this mode, the Enfora Enabler IIIG module supports both of the connection modes of transmission that are provided by GSM:

- Non-Transparent mode delivers a constantly low error rate but with a non-guaranteed throughput or delay. The Non-Transparent service provides a performance that is closest to using a modem over a fixed Public Switched Telephone Network (PSTN) line.

Note: All GSM service providers may not support transparent mode. In those cases, the Enfora Enabler IIIG module can be configured to switch automatically to Non-Transparent mode. This capability depends on the settings in the AT+CBST command.

7.4. SMS: Short Message Services

- Short Message Services (SMS) is a feature-rich GSM service. The Enfora Enabler IIIG module can perform the following tasks:
- Sending and receiving binary messages of up to 160 characters (7-bit characters)
- Sending and receiving text messages of up to 140 bytes (8-bit data)
- Submitting a SMS Protocol Data Unit (PDU) to a SMSC (Short Message Service Center) and storing a copy of the PDU until either a report arrives from the network or a timer expires
- Receiving a SMS PDU from a SMSC
- Returning a delivery report to the network for a previously received message
- Receiving a report from the network
- Notifying the network when the module has sufficient memory capacity available to receive one or more SMS messages (after the module had previously rejected a message because its memory capacity was exceeded)

8. SIM Operation

8.1. Provisioning the SIM

The SIM can support optional features or services. Most operators typically configure the SIM to send/receive voice calls and to receive SMS; however, some may require an additional tariff to enable the SIM to send SMS. The transmission of circuit switched and GPRS data are also additional services that may be required to allow the service:

- Mobile-originated (MO): allows making a service request (such as, making a call or sending an SMS)
- Mobile-terminated (MT): allows receiving a service request (such as, receiving a phone call or an SMS)

It is imperative for the Enfora Enabler IIIG module that the SIM be configured for the optional services that are required for the application.

8.2. GSM Services Supported by the Enfora Enabler IIIG Module

The Enfora Enabler IIIG module supports four GSM services (modes of operation) that must be enabled by the operator:

- Voice calls (MO and MT): requires a telephone number
- SMS (MO and MT): uses the telephone number for Voice
- Circuit-switched data calls (MO and MT): requires a telephone number
- The GSM SIM can have multiple telephone numbers.

8.3. GPRS Services Supported by the Enfora Enabler IIIG Module

The Enfora Enabler IIIG module supports the following GPRS (modes of operation) that must be enabled by the operator:

- GPRS Packet Connectivity (MO and MT) with Both Dynamic and Static IP option
- GPRS SMS (MO and MT): uses the IP (Dynamic or Static) set by the operator
- Multiple APN Setting
- Quality of Service Options
- Multi-slot 10 Class of Service

8.4. Selecting the GSM Modes of Operation

When provisioning the SIM for the Enfora Enabler IIIG module, enable the following modes of operation:

- Voice calls: configure the SIM for both MO and MT service (to send and receive)
- SMS: configure the SIM either for MT alone (to receive) or for both MO and MT (to send and receive)
- Circuit Switched Data: configure the SIM either for MO alone (to send) or for both MO and MT (to send and receive)

Voice	SMS	CS Data	GPRS	Function
MO/MT	MT	MO		Voice calls, receive SMS, make data calls
MO/MT	MO/MT	MO		Voice calls, receive / send SMS, make data calls
MO/MT	MO/MT	MO/MT		Voice calls, receive / send SMS, make / receive data calls (requires an additional data telephone number)

9. Software Interface

9.1. Software Interface

The application sends commands to the Enfora Enabler IIIG module via the 100-pin I/O signal connector. These commands use the Enfora AT Command Set and/or Enfora's Packet API.

The Enfora Enabler IIIG module operates in one of the following modes:

- **Command mode:** Used for configuring the Enfora Enabler IIIG module, for interrogating the GSM network, and for placing and receiving calls. It uses the AT command set via the serial port for communication.
- **On-line mode:** Used after a circuit-switched data call has been established. Data is passed between the Enfora Enabler IIIG module and the controlling application without command interpretation. The only AT command that is interpreted in On-line mode is the +++ command. (This command places the Enfora Enabler IIIG module in Command mode but does not terminate the circuit-switched data call.)
- **IP Packet /API Mode:** Used to read/write modem parameters, interrogate network information, and place and receive calls in real-time, multi-tasking mode. The Packet API mode is facilitated over a PPP connection and the packets can be constructed according to the information provided in the *Enfora GSM-GPRS Family API Reference GSM0308UG001*.

The AT command driver of the Enfora Enabler IIIG module never exits the Command state, that is, it never enters the On-line mode. Although the host interface may not be able to access the AT command interpreter, it is always running and is available via the API Mode over a PPP connection and/or via the RF interface.

- In the Command state, characters that are received from the Customer Premise Equipment (CPE) are treated as AT commands by the Enfora Enabler IIIG module.
- In response to the commands received from the CPE, the Enfora Enabler IIIG module sends characters (AT commands) to the CPE.
- Various events can also trigger the Enfora Enabler IIIG module to send characters (AT commands) to the CPE.

9.2. Format for the AT Commands

The general format of the command line is: **<prefix> <command> <CR>**

<prefix>	AT
<command>	See AT Command Manual
<CR>	0X0D

The prefix AT obtains synchronization, identifies the character parameters, and indicates that a command may be in the following characters.

AT commands are not case sensitive: use either capital letters or lower-case letters for the AT command.

Note: Some AT Command parameter values **ARE** case sensitive and are documented in the Enfora **Enabler-IIIG AT Command Set Reference – GSM0308AT001**.

9.3. Enfora AT Command Set

For a full description of the AT commands, refer to the Enfora ***GSM0308AT001 - Enabler-III AT Command Set***.

Note: A command description that includes an *asterisk denotes that the GSM service provider must enable supplementary services functionality before the command is available.

9.4. Enfora Packet Application Programming Interface

9.4.1. API Architecture

For description and overview of the Enfora UDP and TCP-based API architecture please refer to the ***GSM0308UG001 - Enfora GSM-GPRS Family -API Reference***.

10. Setup and Initialization

10.1. General Setup

The GPRS modem is controlled through the Modem RS232 port on the development board. Connect a nine pin straight through serial cable from the Modem RS232 connector to the serial port on the controlling computer.

Hook up power supply, connect antenna, and install SIM into modem.

10.1.1. HyperTerminal Configuration for Enabler IIIG module

The following provides an example for setting up a Windows HyperTerminal session that can be used to experiment with various configurations on the Enabler IIIG module for controlling computer:

1. Select the connection interface, Direct to Com 1 (or whatever port is the serial port).



Figure 20 – Hyper Terminal Definition

2. Configure the COM port as displayed below.

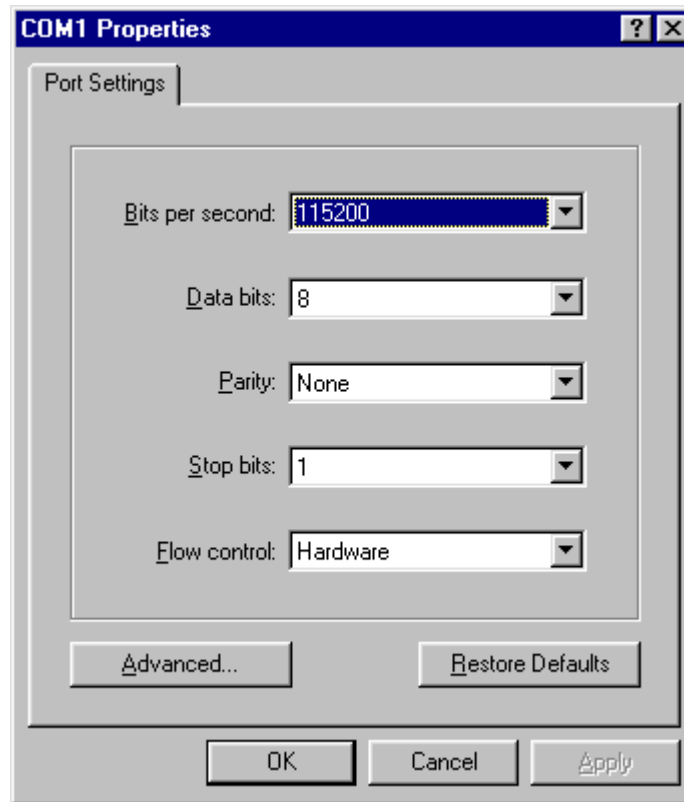

Figure 21 - COM Port Settings

10.1.2. Initialization (AT Command Interface)

In the GSM vocabulary, a call from GSM mobile to the PSTN is called a "mobile-originated call" or "outgoing call". A call from the fixed network to a GSM mobile is called a "mobile-terminated call" or "incoming call."

In the following examples, "Entry" refers to the application. The following convention describes the direction of the data exchange:

- The data exchange from the customer application to the Enfora Enabler IIIG module is designated as:

Entry

The data exchange from the Enfora Enabler IIIG module to the customer application is designated as:

Response

Note: With the exception of the +++ command (Online Escape Sequence), all commands must be preceded by the AT attention code (or command prefix) and terminated by pressing the <CR> character.

In the following examples, the <CR> and <CR><LF> are intentionally omitted for clarity and space.

10.1.3. Initial Response to the AT Command

After power is applied to the Enfora Enabler IIIG module, the module performs a power-up self-test. The self-test completes within one (1) second. When queried with the AT command, the Enfora Enabler IIIG module responds with one of the following result codes:

- OK signifies that the Enfora Enabler IIIG module is ready, that it correctly interprets the AT command, and that it has executed the command.
- ERROR signifies that the Enfora Enabler IIIG module does not understand the command or that the command is invalid.

Entry	AT	
Response	OK	Command valid: module is ready

The Enfora Enabler IIIG module must be in AT Command mode (please refer to section 10.3 GPRS Packet Examples for packet mode initialization and setup) when any command is entered (with the exception of the online escape sequence). Commands entered when the module is in On-line mode are treated as data, and are transmitted as such to the receiving module. i.e. If the module is in PPP or SLIP mode, AT commands cannot be entered.

10.1.4. Sending an Initialization String to the Enfora Enabler IIIG Module

The following example provides the sample AT commands and responses for the following initialization tasks:

- Reset the module to the factory defaults
- Disable character echo
- Transmit Result Codes
- Set the module to Verbose mode (to display result codes as words)
- Set the DCD to match the state of remote modem
- Ignore the DTR

Entry	AT&FE0Q0V1&C1&d0	Initialization string
Response	OK	Command is valid
Entry	ATSO=1	Auto answer on 1st ring
Response	OK	Command is valid

10.1.5. Setting Up the Communication Mode for the Enfora Enabler IIIG Module

The following example sequence provides the AT command and response for setting the Enfora Enabler IIIG module for full phone functionality, automated operator selection, 9600 baud, non-transparent mode.

Entry	AT+CFUN=1	FULL phone functionality
Response	OK	Command is valid
Entry	AT+COPS=0	Automatic operator selection
Response	OK	Command is valid
Entry	AT+CBST=7,0,1	9600 baud, non-transparent mode
Response	OK	Command is valid

10.1.6. Querying the Status of the Enfora Enabler IIIG Module

This topic is addressed in the Enfora Application Note *GSM0000AN006 – Enabler-G Module Status Query*.

10.1.7. Setting Module Reporting Parameters for GSM and GPRS

This topic is addressed in the Enfora Application Note *GSM0000AN007 - Enabler-G Status Reporting*.

10.2. GSM/SMS Examples

10.2.1. Initialize the Enfora Enabler IIIG Module to Send and Receive SMS Text Messages

This topic is addressed in the Enfora Application Note *GSM0000AN004 - Enabler-G SMS Configuration and Use*.

10.2.2. Managing SMS Messages

This topic is addressed in the Enfora Application Note *GSM0000AN004 - Enabler-G SMS Configuration and Use*.

10.2.3. Data Call Configuration

This topic is addressed in the Enfora Application Note *GSM0000AN003 - Enabler-G Data Circuit Switched Call Configuration and Use*.

10.2.4. Voice Call Configuration

This topic is addressed in the Enfora Application Note *GSM0000AN003 - Enabler-G Data Circuit Switched Call Configuration and Use*.

10.3. GPRS Packet Examples

10.3.1. GPRS ATTACH and ACTIVATE

This topic is addressed in the Enfora Application Note *GSM0000AN005 - Enabler-G Automated Network Connection Configuration and Use*.

10.3.2. Windows PPP Setup

The Enabler IIIG module can be used in a Windows operating system environment as a standard serial modem device. The required setup and configuration process is contained in Enfora Application Notes *GSM0000AN001 - Enabler-G PPP Configuration for Windows 98* and *GSM0000AN002 - Enabler-G PPP Configuration for Windows 2000*.

11. Integration and Testing

The Enfora Enabler IIIG module has been designed to minimize the amount of time required for integration and testing the application. By being fully certified by the appropriate bodies, the Enfora Enabler IIIG module provides seamless integration into the GSM network.

The integration issues for the application can be narrowed to the utilization of the AT commands and the use of the GSM functionality. Coverage and signal quality may be evaluated by using the RSSI commands. Additional network information can be determined by using AT commands.

Integration of the GPRS Packet capabilities is more complicated than using AT command sequences to initiate the connection and begin transferring data. The following Application Notes should be used to integrate the GPRS packet capabilities:

GSM0000AN001 - Enabler-G PPP Configuration for Windows 98

GSM0000AN002 - Enabler-G PPP Configuration for Windows 2000

GSM0000AN008 - Enabler-G PPP Configuration for Windows XP

GSM0000AN010 - Enabler-G PPP Configuration for PocketPC 2002

GSM0000AN005 - Enabler-G Automated Network Connection Configuration and Use

11.1. Integrating the Enfora Enabler IIIG Module

Note: Generally, all interfaces that are externally available to the end user need to be ESD-conditioned and terminated in some way. Many of these interfaces should not be connected with power applied.

At the highest level, this is done using some type of GSM test equipment (such as, Racal 6103E), a computer, and a serial interface tester. The GSM test equipment must be able to simulate a GSM call and measure the key parameters related to the module.

Additionally, the serial interfaces and some minimal SIM functionality can be verified by sending AT commands to the Enfora Enabler IIIG module.

All of these conditions need to be verified at ambient as well as extreme conditions.

As part of integration, each of the following interfaces must be verified:

Information	Recommendations
SIM	<p>The maximum line length of the SIM interface is 25.4 cm (10 inches).</p> <p>The Enfora Enabler IIIG module takes care of the signal conditioning</p> <p>As a minimum, an external application with a remote SIM will require a standard SIM carrier.</p> <p>Filter the SIM VCC signal with a 10 uf / 10 V capacitor to help with the line length.</p>
Primary and secondary serial interfaces	The Enfora Enabler IIIG module uses a 1.8V digital interface. The RS-232 signals must be level-shifted to get standard levels. These signals must be ESD-protected.
Reset Interface	Resets the Enfora Enabler IIIG module when tied low.
Audio/Microphone Interface	Preliminary balancing on Enfora Enabler IIIG module. Maximum length TBD

Testing the following parameters verifies the RF parameters that may be affected by such things as RF path loss, power supply noise, and external interference.

Functionality	Parameters to be Tested
Transmitter	<p>Frequency Error</p> <p>Phase Error</p> <p>PA Ramp</p> <p>Modulation Spectrum</p> <p>RF Power Steps</p> <p>Timing Advance</p>
Receiver	<p>BER Based RX Tests (RXQUAL RXLEV)</p> <p>BER Based Sensitivity</p>

Testing the following GSM functionality verifies proper network communication.

Functionality	Parameters to be Tested
Transmitter	<p>Frequency Error</p> <p>Phase Error</p> <p>PA Ramp</p> <p>Modulation Spectrum</p> <p>RF Power Steps</p> <p>Timing Advance</p>
Receiver	<p>BER Based RX Tests (RXQUAL RXLEV)</p> <p>BER Based Sensitivity</p>

Testing the following GSM functionality verifies proper network communication.

Functionality	Parameters to be Tested
Network Function	<p>Synchronization and registration</p> <p>Call set-up and call termination (both MT and MO calls)</p> <p>SMS and/or data calls</p>

12. APPENDIX A - LIMITED WARRANTY

12.1. Scope

Enfora warrants to the original purchaser of the product that, for a period of one (1) year from the date of product purchase, the product hardware, when used in conjunction with any associated software (including any firmware and applications) supplied by Enfora, will be free from defects in material or workmanship under normal operation. Enfora further warrants to such original purchaser that, for a period of ninety (90) days from the date of product purchase, any software associated with the product will perform substantially in accordance with the user documentation provided by Enfora, and any software media provided with the product will be free from defects in material or workmanship under normal operation. Enfora does not warrant that (a) the product hardware or any associated software will meet the purchaser's requirements, (b) that the operation of the product hardware or software will be uninterrupted or error-free, or (c) the product, when integrated in, or combined with, other products or software not supplied by Enfora, will continue to perform substantially in accordance with the user documentation. This limited warranty is only for the benefit of the original purchaser and is not transferable. No other party may act on behalf of such purchaser for the purpose of claiming or exercising any rights or benefits under or in connection with this limited warranty except as may be provided in a written agreement between Enfora and such other party.

12.2. Hardware

During the warranty period applicable to the product hardware, Enfora, at its expense and in its sole discretion, will repair or replace the product if it is determined to have a covered hardware defect, provided that the purchaser first notifies Enfora of any such defect, furnishes Enfora with a proof of purchase, requests and obtains a return merchandise authorization (RMA) number from Enfora, and returns the product, shipping charges prepaid, to Enfora under that RMA. If, upon reasonable examination of the returned product, Enfora does not substantiate the defect claimed by purchaser, or determines that the defect is not covered under this limited warranty, Enfora will not be required to repair or replace the product, but may instead reship the product to the purchaser, in which case purchaser shall be responsible for paying Enfora's usual charges for unpacking, testing, and repacking the product for reshipment to purchaser. Purchaser shall bear the risk of loss or damage in transit to any product returned by purchaser to Enfora, or any returned product not found to be defective or covered under this warranty and reshipped by Enfora to purchaser. In the event Enfora repairs or replaces a defective product, the repaired or replacement product will be covered under this limited warranty for the remainder of the original warranty period on the defective product. If Enfora is unable to repair or replace a defective product, the purchaser's exclusive remedy shall be a refund of the original purchase price. Any returned and replaced product, or any product for which Enfora has refunded the original purchase price, becomes the property of Enfora.

12.3. Software

During the warranty period applicable to the software or its media, Enfora, at its expense, will replace any defective software or media if purchaser gives written notification of the defect to the technical support department at Enfora during the applicable warranty period. Enfora will ship or otherwise transmit the replacement software or media to purchaser, and purchaser shall be responsible for incorporating any replacement software in the product. Enfora shall not have any obligation to provide any software bug fixes, upgrades or new releases except as may be necessary to correct any covered defect of which purchaser notifies Enfora in writing during the applicable warranty period. Enfora, from time to time and in its sole discretion, may make available for download on its website (www.enfora.com) certain software bug fixes, upgrades or new releases for the product. The purchaser should periodically visit such website to determine whether any such bug fixes, upgrades or new releases have become available. Download and use of any such bug fixes, upgrades or new

releases is subject to all of the applicable terms and conditions of Enfora's technical support policy as posted and updated on its website.

Exceptions and Disclaimers

Enfora shall have no obligation under this limited warranty for (a) normal wear and tear, (b) the cost of procurement of substitute products or (c) any defect that is (i) discovered by purchaser during the warranty period but purchaser does not notify or request an RMA number from Enfora, as required above, until after the end of the warranty period, (ii) caused by any accident, misuse, abuse, improper installation, handling or testing, or unauthorized repair or modification of the product, (iii) caused by use of any software other than any software supplied by Enfora, or by use of the product other than in accordance with its documentation or (iv) the result of electrostatic discharge, electrical surge, fire, flood or similar causes. Unless otherwise provided in a written agreement between the purchaser and Enfora, the purchaser shall be solely responsible for the proper configuration, testing and verification of the product prior to deployment in the field.

ENFORA'S SOLE RESPONSIBILITY AND PURCHASER'S SOLE REMEDY UNDER THIS LIMITED WARRANTY SHALL BE TO REPAIR OR REPLACE THE PRODUCT HARDWARE, SOFTWARE OR SOFTWARE MEDIA (OR IF REPAIR OR REPLACEMENT IS NOT POSSIBLE, OBTAIN A REFUND OF THE PURCHASE PRICE) AS PROVIDED ABOVE. ENFORA EXPRESSLY DISCLAIMS ALL OTHER WARRANTIES OF ANY KIND, EXPRESS OR IMPLIED, INCLUDING WITHOUT LIMITATION ANY IMPLIED WARRANTIES OF NON-INFRINGEMENT, MERCHANTABILITY, SATISFACTORY PERFORMANCE AND FITNESS FOR A PARTICULAR PURPOSE. IN NO EVENT SHALL ENFORA BE LIABLE FOR ANY INDIRECT, SPECIAL, EXEMPLARY, INCIDENTAL OR CONSEQUENTIAL DAMAGES (INCLUDING WITHOUT LIMITATION LOSS OR INTERRUPTION OF USE, DATA, REVENUES OR PROFITS) RESULTING FROM A BREACH OF THIS WARRANTY OR BASED ON ANY OTHER LEGAL THEORY, EVEN IF ENFORA HAS BEEN ADVISED OF THE POSSIBILITY OR LIKELIHOOD OF SUCH DAMAGES.

12.4. Other Considerations

Some jurisdictions may require a longer warranty period than specified above and, accordingly, for products sold in those jurisdictions the applicable warranty period shall be extended as required under the laws of those jurisdictions. Furthermore, some jurisdictions may not allow the disclaimer of implied warranties or the exclusion or limitation of incidental or consequential damages, so the above disclaimer, limitation or exclusion may not apply to products sold in those jurisdictions. This limited warranty gives the purchaser specific legal rights and the purchaser may have other legal rights that vary from jurisdiction to jurisdiction.

In some instances, certain aspects of the product warranty may also be covered in a separate written agreement between Enfora and the distributor or reseller, if any, from whom purchaser purchased the product. That agreement may provide, for example, a different product return procedure that may also be available to purchaser (e.g., the product may be returned to Enfora through that distributor or reseller).

Governing Law

This limited warranty shall be governed by the laws of the State of Texas, United States of America, without regard to conflict of laws principles. This limited warranty shall not be governed in any respect by the United Nations Convention on Contracts for the International Sale of Goods.

13. APPENDIX B - Regulations and Compliance

This section summarizes the responsibilities and actions required of manufacturers and integrators who incorporate OEM versions of the Enfora Enabler IIIG module into their products. In certain situations and applications, these products will require additional FCC, CE, GCF, PTCRB or other regulatory approvals prior to sale or operation. Appropriate instructions, documentation and labels are required for all products. For more information concerning regulatory requirements, please contact Enfora.

13.1. GCF/PTCRB Approval (Formerly FTA)

The Enfora Enabler IIIG module is type approved in accordance with the requirements of and through the procedures set forth by the GSM industry association. The relevant conformance specification is 3GPP TS 51010-1. Any OEM changes in the SIM interface, antenna port, software or the physical makeup of the unit may require an incremental FTA to ensure continued compliance with the above-mentioned standard. For more information concerning type approval, please contact Enfora.

13.2. Electromagnetic Compatibility (EMC) and Safety Requirements

The Enfora Enabler IIIG module has been tested and approved for application in the United States of America (US) and the European Union (EU). The compliance details for each of these markets follow. For other markets, additional or alternative regulatory approvals may be required. Always ensure that all rules and regulations are complied with in every country that the OEM application is to be operated. Regardless of the country or market, the OEM must comply with all applicable regulatory requirements.

13.3. EMC/Safety Requirements for the USA

Compliance to the US rules and regulations falls under two categories:

- Radio approvals: Federal Communications Commission (FCC)
- Transmitter: FCC Rules, Part 22 & 24
- Unintentional emission: FCC Rules, Part 15

Although the Enfora Enabler IIIG module has been authorized by the FCC and listed as a component by an NRTL, products and applications that incorporate the Enfora Enabler IIIG module will require final verification of EM emission and product safety approval.

Note: Particular attention should be made to the following statements regarding RF Exposure:

13.4. Human Exposure Compliance Statement

GSM0308 GSM/GPRS Module

Enfora certifies that the Enfora Enabler IIIG 850/900/1800/1900 MHz GSM Radio Module (FCC ID: MIVGSM0308) complies with the RF hazard requirements applicable to broadband PCS equipment operating under the authority of 47 CFR Part 24, Subpart E and Part 22 of the FCC Rules and Regulations. This certification is contingent upon installation, operation and use of the Enfora Enabler IIIG module and its host product in accordance with all instructions provided to both the OEM and end user. When installed and operated in a manner consistent with the instructions provided, the Enfora Enabler IIIG module meets the maximum permissible exposure (MPE) limits for general population / uncontrolled exposure at defined in Section 1.1310 of the FCC Rules and Regulations.

Note: Installation and operation of this equipment must comply with all applicable FCC Rules and Regulations, including those that implement the National Environmental Policy Act of 1969 (Part 1, Subpart I), with specific regard to antenna siting and human exposure to radio frequency radiation. For further guidance, consult the FCC Rules, a certified FCC test house, or Enfora.

13.5. Compliance with FCC Regulations

The Federal Communications Commission (FCC) is the agency of the Federal Government that oversees all non-governmental radio frequency transmitters that operate within the United States. Unintentional emissions from digital devices are regulated by Part 15 of the FCC Rules and Regulations, which distinguishes between the environments in which these devices may operate. Intentional radiators operating as a GSM-1900 radio transmitter are regulated under Part 22 & 24, Subpart E—Broadband PCS of the FCC Rules and Regulations.

13.6. Unintentional Radiators, Part 15

Equipment designated as Class A is intended for use in a commercial, industrial or business environment. The Enfora Enabler IIIG module has been tested and found to comply with the limits for a Class A digital device and can be integrated into equipment or applications intended for use in commercial, industrial or business environments.

The following statement must be included in the user manual for such products:

This equipment has been tested and found to comply with the limits for a Class A digital device, pursuant to part 15 of the FCC rules. These limits are designed to provide reasonable protection against harmful interference when the equipment is operated in a commercial environment. This equipment generates, uses, and can radiate radio frequency energy and, if not installed and used in accordance with the instruction manual, may cause harmful interference to radio communications. Operation of this equipment in a residential area is likely to cause harmful interference in which case the user will be required to correct the interference at his own expense.

Equipment intended for use in a residential environment (notwithstanding use in commercial, industrial or business environments) is designated as Class B. The Enfora Enabler IIIG module has been tested and found to comply with the limits for a Class B digital device and can be integrated into equipment or applications intended for use in residential environments.

The following statement must be included in the user manual for such products:

This equipment has been tested and found to comply with the limits for a Class B digital device, pursuant to part 15 of the FCC rules. These limits are designed to provide reasonable protection against harmful interference in a residential installation. This equipment generates, uses, and can radiate radio frequency energy and, if not installed and used in accordance with the instructions, may cause harmful interference to radio communications. However, there is no guarantee that interference will not occur in a particular installation. If this equipment does cause harmful interference to radio or television reception, which can be determined by turning the equipment off and on the user is encouraged to try to correct the interference by one or more of the following measures:

- Reorient or relocate the receiving antenna.
- Increase the separation between the equipment and receiver.
- Connect the equipment into an outlet on a circuit different from that to which the receiver is connected.
- Consult the dealer or an experienced radio/TV technician for help.

13.7. Intentional Radiators, Part 22 & 24

Products incorporating the Enfora Enabler IIIG transceiver operate as Personal Communications Services (PCS) devices under the authority of Part 22 & Part 24, Subpart E—Broadband PCS, of the FCC Rules and Regulations. All such transmitters must be authorized by the FCC through its Certification process, as detailed in Part 2, Subpart J - Equipment Authorization Procedures. Through the Certification process, the FCC verifies that the product complies with all applicable regulatory and technical requirements, including those that address human exposure to radio frequency radiation. In general, radio frequency transmitters cannot be sold or operated in the US prior to FCC approval.

13.8. Instructions to the Original Equipment Manufacturer (OEM)

To comply with the requirements of the National Environmental Policy Act (NEPA) of 1969, operation of an FCC-regulated transmitter may not result in human exposure to radio frequency radiation in excess of the applicable health and safety guidelines established by the FCC. Further information on RF exposure issues may be found in the FCC's Office of Engineering and Technology (OET) Bulletin Number 65, "Evaluating Compliance with FCC Guidelines for Human Exposure to Radio Frequency Electromagnetic Fields" and Supplement C, "Additional Information for Evaluating Compliance of Mobile and Portable devices with FCC Limits for Human Exposure to Radio Frequency Emissions." Both of these documents are available via the Internet at the OET web site: <http://www.fcc.gov/oet>

The Enfora Enabler IIIIG products are GSM radio transceivers, which operate under the authority of 47 CFR Part 24, Subpart E and Part 22 of the FCC Rules and Regulations. When installed and operated in accordance with the instructions provided in this manual, these devices comply with current FCC regulations regarding human exposure to radio frequency radiation.

The following installation and operation restrictions apply to all Enfora Enabler IIIIG products:

- This device may only be used in fixed and mobile applications.
- Portable applications, as defined by the FCC, are prohibited.
- The use of this device for desktop and other applications where the antenna can easily be relocated are considered by the FCC to be mobile applications.
- A separation distance of at least 20 cm (7.87 inches) between the antenna and the body of the user and other persons must be maintained at all times
- In FIXED applications, *antenna gain* is limited to a maximum of 7 dBi, with a corresponding Equivalent Isotropic Radiated Power (EIRP) of 37 dBm / 5 W.
- In MOBILE applications, *antenna gain* is limited to a maximum of 2 dBi, with a corresponding EIRP of 33 dBm / 2 W.
- End products must provide instructions to ensure compliance with radio frequency radiation exposure requirements.
- A warning label visible to all persons exposed to the antenna and identical to that described in this manual must be displayed on or next to the antenna.
- Separate FCC approval for RF exposure compliance is required for end products that do not meet these conditions.

Antenna gain is defined as gain in dBi (dB referenced to an isotropic radiator) minus cabling loss.

Note: Additional care must be taken by the installer and/or user of the Enfora Enabler IIIIG products to ensure proper antenna selection and installation. Adherence to the above conditions is necessary to comply with FCC requirements for safe operation regarding exposure to RF radiation.

Depending upon the application and type of product into which the Enfora Enabler IIIIG module has been incorporated, specific OEM actions and responsibilities required to meet these conditions vary. However, in all cases the primary concern is to ensure compliance with current FCC guidelines and regulations that limit human exposure to radio frequency radiation.

Definitions

For the purpose of determining compliance with current FCC rules addressing human exposure to radio frequency radiation, the FCC has established the following three categories of transmitting devices:

- Portable Devices – devices where the antenna is located within 20 cm (7.87 inches) of any person, including the user, if applicable. Portable devices operating under the authority of Part 22 or 24 (broadband PCS) are limited to a maximum of 2 W EIRP.
- Mobile Devices – devices designed to be used in other than fixed locations and generally such that the antenna is located at a minimum of 20 cm (7.87 inches) from any person, including the user, if applicable. Mobile devices operating under the authority of Part 22 or 24 (broadband PCS) are limited to a maximum of 2 W EIRP.
- Fixed devices – devices in which the antenna, either integral to the product or remotely located, is physically secured at one location and is not able to be easily moved to another location. The antenna for a fixed device is mounted on an outdoor permanent structure with a minimum separation distance of 2 meters (79 inches)

13.8.1. OEM Responsibilities for All Products Containing the Enabler IIIG module

In addition to any other regulatory requirements, OEMs and integrators must include or provide the following information, instructions, warnings and labels with any device or product into which the Enfora Enabler IIIG GSM1900 GSM transceiver has been incorporated:

Information	Description	
Detailed Operating Instructions for ensuring compliance with current FCC guidelines which limit human exposure to radio frequency radiation	<p>The OEM must provide an operating/installation manual with the final product which clearly indicates that these operating conditions and restrictions must be observed at all times to ensure compliance with current FCC guidelines which limit human exposure to radio frequency radiation.</p> <p>20 cm (7.87 inch) separation distance between the antenna and all persons must be maintained at all times for all fixed and mobile products and applications</p> <p>Portable devices and applications are prohibited unless such devices and products are specifically authorized by the FCC</p> <p>Maximum antenna gain is limited to 2 dBi* in mobile products and applications</p> <p>For fixed applications (2 meter separation) the antenna gain can be as much as 26 dBi.</p> <p>Modifications and/or additions to the Enfora Enabler IIIG GSM transceiver, including use of antennas with higher gain than those authorized by the FCC, are prohibited</p> <p>*dBi = antenna gain in dB relative to an isotropic radiator</p>	
Antenna Avoidance Label	Attach the following warning label directly to or displayed next to the antenna. Furthermore, this label must be visible to and easily readable by all persons in the immediate vicinity of the antenna	WARNING To comply with FCC RF exposure requirements, a separation distance of 20 cm (7.87") or more must be maintained between this antenna and all persons
Human Exposure Compliance Statement	Include the following statement in the instruction / operation manual.	Enfora certifies that the Enfora Enabler IIIG™ MHz GSM Radio Module (FCC ID: MIVGSM0308) complies with the RF hazard requirements applicable to broadband PCS equipment operating under the authority of 47 CFR Part 22 or Part 24, Subpart E of the FCC Rules and Regulations. This certification is contingent upon installation, operation and use of the Enfora Enabler IIIG module and its host product in accordance with all instructions provided to both the OEM and end user. When installed and operated in a manner consistent with the instructions provided, the Enfora Enabler IIIG module meets the maximum permissible exposure (MPE) limits for general population / uncontrolled exposure as defined in Section 1.1310 of the FCC Rules and Regulations.

13.8.2. Specific OEM Responsibilities for Portable Products and Applications

Each device or product, into which the Enfora Enabler IIIG PCS-1900 GSM transceiver has been incorporated, and which is intended to be used in an application that meets the definition of "portable" MUST be separately authorized by the FCC for the purposes of determining compliance with current FCC guidelines limiting human exposure to radio frequency radiation.

Portable devices must be evaluated for RF exposure based on Specific Absorption Rate (SAR) limits; further information on such evaluations are available from the FCC via the Internet.

13.8.3. Specific OEM Responsibilities for Mobile Products and Applications

Separate or additional FCC approvals are NOT required for devices or products, into which the Enfora Enabler IIIG PCS-1900 GSM transceiver has been incorporated, that are used in applications that meet the definition of "mobile."

For all end products, the OEM or integrator must provide instructions, warnings and labels to ensure that the product complies with current FCC guidelines limiting human exposure to radio frequency radiation.

Current FCC regulations limit the EIRP of mobile devices to 2 W. Because the nominal RF output power of the Enfora Enabler IIIG GSM1900 GSM transceiver is 1.0 W (31 dBm), antenna gain for mobile products and applications cannot exceed 2 dBi.

13.8.4. Specific OEM Responsibilities for Fixed Products and Applications

Separate or additional FCC approvals are not required for devices or products, into which the Enfora Enabler IIIG GSM transceiver has been incorporated, that are used in applications that meet the definition of "fixed."

For all end products, the OEM or integrator must provide the instructions, warnings and labels to ensure that the product complies with current FCC guidelines limiting human exposure to radio frequency radiation.

Separate or additional FCC approvals are required for devices or end products used in fixed applications where antenna gain in excess of 7dBi is desired.

13.9. EMC/Safety Requirements for the Countries of the European Union (EU)

The European Union (EU) is comprised of fifteen countries that follow a harmonized set of standards, utilizing the CE mark as a uniform mark of acceptance. The member countries are:

- Austria
- Belgium
- Cyprus
- Czech Republic
- Denmark
- Estonia
- Finland
- France
- Germany
- Greece
- Hungary
- Ireland
- Italy
- Latvia
- Lithuania
- Luxembourg
- The Netherlands
- Poland
- Portugal
- Slovakia
- Slovenia
- Spain
- Sweden
- United Kingdom

13.10. EMC/Safety Requirements for Other Countries

In most other countries that have not been listed above there are similar rules and regulations that must be met for importing the Enfora Enabler IIIG module. Each may require a different mark of approval (for example, the CB Scheme) as an acceptance requirement. For each of these cases the country should be identified, and the appropriate steps should be taken to meet the requirements set forth in the intended market.

14. APPENDIX C - Glossary and Acronyms

API	Application Programming Interface.
App Application	Refers to the Application which sends or receives commands/responses from the Enfora Enabler IIIG Module
AT Command Set	Commands issued by intelligent device to a modem to perform functions, such as to initiate call, to answer call, or to transmit data.
BER Bit Error Rate	Bit Error Rate
CMUX	Multiplexer protocol that operates between an MS and a TE and allows a number of simultaneous sessions over a normal serial asynchronous interface
CPE Customer Premise Equipment	A terminal in fixed location on the customer's premises.
CSD Circuit Switched Data	Data link from a terminal through the network allowing real-time, duplex connectivity at 9600 bytes/second.
dBi	Decibels referenced to an isotropic radiator
DCE Data Communications Equipment	Data Communications Equipment
DCS Digital Cellular System	A collection of services and capabilities providing flexibility of access and mobility through a combination of wireless and wire-line networks, utilizing the 1800 MHz bandwidth.
DTE Data Terminal Equipment	Data Terminal Equipment
EFR Enhanced Full Rate	Voice (vocoder) compression algorithms which offer the highest quality voice communication.
EIR Equipment Identity Register	A database used to store International Mobile Equipment Identity (IMEI) of a locally issued terminal.
EIRP Equivalent Isotropic Radiated Power	In a given direction, the gain of a transmitting antenna multiplied by the net power accepted by the antenna from the connected transmitter.
EMC Electromagnetic Compatibility	The ability of a device to function satisfactorily in its electromagnetic environment without inducing intolerable disturbance to that environment (or to other devices)
ESD Electrostatic Discharge	Static electricity that can damage electronic equipment.
EU European Union	An organization of 15 European states whose purpose is to organize relations between the Member States and between their peoples.
FTA Full Type Approval	GSM Full Type Approval
GPRS General Packet Radio Service	Standard for packet communications utilizing Global Standard for Mobility (GSM) infrastructure.
GSM Global System for Mobile Communications	Standard for digital communications. Allows consistent communications in various parts of the world despite variations in RF spectrum allocations. Transferring the SIM (see below) permits users to roam by changing terminal equipment.
HLR Home Location Register	Stores the identity and user data for all subscribers belonging to the area of the related MSC.

IMEI International Mobile Equipment Identity	A unique number for each GSM Terminal tracked by the GSM operators in their Equipment Identity Register (EIR) database.
IMSI International Mobile Subscriber Identification	A unique number identifying the subscriber stored in the SIM card. Number is used in conjunction with the network for call routing.
Ki	A secret code used in authentication and encryption by the terminal.
MO Mobile Originated	Any GSM/GPRS service originated at the mobile terminal.
MT Mobile Terminated	Any GSM/GPRS service originated from or routed through the network and sent to the mobile terminal.
MSC Mobile Switching Center	The central switch of the GSM network. Performs call routing, collects call detail records for billing, and supervises system operations.
Non-Transparent Mode	Delivers a constantly low error rate but with a non-guaranteed throughput or delay. The Non-Transparent service provides a performance that is closest to using a modem over a fixed PSTN line.
NRTL Nationally Recognized Test Laboratory	OSHA-approved Nationally Recognized Testing Laboratory
OEM	Original Equipment Manufacturer.
PA	Power Amplifier.
Packet	A collection of data transmitted over a digital network in a burst.
PCS	Personal Communication Services.
PDA	Personal Digital Assistant.
PDU	Packet Data Unit.
PPP	Point-To-Point Protocol.
SIM	Subscriber Identity Module.
SMS	Short Message Service.
SMSC	Short Message Service Center.
SUPL	Secure User Plane Location
UDP	User Datagram Protocol.

15. APPENDIX D – Tables and Figures

TABLES

Table 1 - Enabler IIIG Key Features	9
Table 2 - Enabler IIIG Pin Assignments.....	33

FIGURES

Figure 1 - Example of good ground plane for GSM modules	15
Figure 2 - Example of a POOR RF Thermal Relief.....	16
Figure 3 - Example of a GOOD RF Thermal Relief	17
Figure 4 - Example of Vbat Voltage Droop	18
Figure 5 - Example of GOOD Vbat layout.....	19
Figure 6 - Audio Reference Design Schematic.....	20
Figure 7 - Enabler IIIG Module Block Diagram	22
Figure 8 – Front of Module (Board-to-Board RF Conn. Version).....	25
Figure 9 - Pin 1 Reference, 100-Pin I/O Connector	26
Figure 10 – Front of Module (Coaxial RF Conn. Version)	27
Figure 11 - Back of Module (Option SIM Shown)	28
Figure 12 – Module Mounting	29
Figure 13 - Host Pads for Board-To-Board RF Connector	30
Figure 14 – Modem Mounting Pads.....	31
Figure 15 – Power Control Switch	39
Figure 16 - External Power Control Signal (no external processor)	40
Figure 17 - Power Control Signal (using external processor).....	41
Figure 18 - Ring Indicate Timing.....	47
Figure 19 - Remote SIM Interface.....	56
Figure 20 – Hyper Terminal Definition	65
Figure 21 - COM Port Settings.....	66

16. APPENDIX E - Contacting Enfora

For technical support and customer service dealing with the modem itself, contact the company where you purchased the product. If you purchased the product directly from Enfora, visit the SUPPORT page on the Enfora website: http://www.enfora.com/support_newissue.asp