

ACUTIME GOLD

KEY FEATURES

- Stratum 1 time source
- Network synchronization
- Timing pulse synchronized to within 15 nanoseconds (one sigma) of GPS/UTC
- Operating temp -40 °C to +85 °C
- Waterproof and corrosion resistant housing
- RoHS-Compliant (Pb-free)



The Acutime Gold is the premier time source for synchronization of wireless networks.

GPS SMART ANTENNA FOR PRECISE TIMING AND SYNCHRONIZATION

The Trimble® Acutime™ Gold GPS smart antenna marks the integration of the latest GPS technology into a rugged self-contained unit that enables easy integration into any system. The Acutime Gold is a pipe thread-mounted GPS receiver and antenna in a single environmentally sealed enclosure.

The Acutime Gold GPS smart antenna design continues the Trimble line of GPS smart antennas, which have been in production since 1991. This GPS smart antenna is the perfect solution for precise timing and network synchronization needs, including broadband wireless applications. It provides a cost-effective and independent timing source (within the firewall) for any application, such as fault detection systems and synchronization of wireless networks.

Once power is applied, the Acutime Gold smart antenna automatically tracks satellites and surveys its position to within meters. It then switches to overdetermined time mode and generates a pulse-per-second (PPS) output synchronized to UTC within 15 nanoseconds (one sigma), outputting

a time tag for each pulse. The Acutime Gold GPS smart antenna's T-RAIM (Time-Receiver Autonomous Integrity Monitor) algorithm ensures PPS integrity.

Designed for long-term reliability, the Acutime Gold GPS smart antenna is corrosion-resistant and waterproof, and has a rounded top that facilitates run-off from the elements.

Physical Interface

The RS-422 interface is ideal for long cable runs required by buildings or towers. Standard cables are available in lengths up to 400 feet. Custom lengths up to 1800 feet may be ordered.

Getting Started

The Acutime Gold Starter Kit makes it easy to evaluate the exceptional performance of this GPS smart antenna and integrate state-of-the-art technology into your system. The Starter Kit includes the Acutime Gold GPS smart antenna (RS-422), a 100' interface cable, user guide, RS-422 to USB converter, and a Microsoft® Windows® software tool for monitoring and communication.

PHYSICAL CHARACTERISTICS

Dimensions 3.74" D, 2.85" H (95 mm x 72.5 mm)
 Weight 5.4 oz (154 g)
 Connector 12-pin round, waterproof
 Mounting 1"-14" straight thread or 3/4" pipe thread
 Mechanical drawing

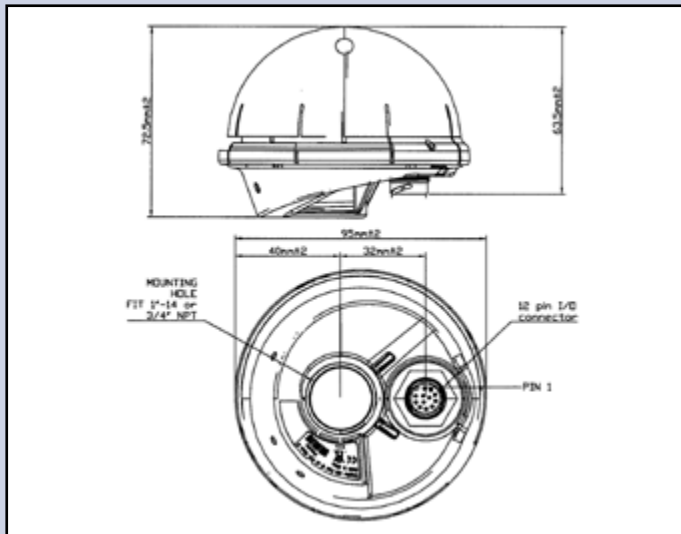

ENVIRONMENTAL SPECIFICATIONS

Operating temp: -40 °C to +85 °C
 Storage temp: -55 °C to +105 °C
 Vibration: 0.008 g2/Hz 5 Hz to 20 Hz
 0.05 g2/Hz 20 Hz to 100 Hz
 -3dB/octave 100 Hz to 900 Hz
 Operating humidity: 95% RH, non-condensing @ 60 °C
 EMC: CE, FCC Class B
 Ingress Protection: IP x7

PERFORMANCE SPECIFICATIONS

General: L1 frequency, C/A code (SPS), continuous tracking receiver, static overdetermined clock mode (default)
 Update Rate 1 Hz
 Event Update Rate max 5 Hz/second
 Accuracy Horizontal Position <6 meters (50%) <9 meters (90%)
 Accuracy Altitude Position <11 meters (50%) <18 meters (90%)
 Velocity 0.06 m/sec
 Time to First Fix (no stored position) <46 sec. (50%) <50 sec. (90%)
 Time to First PPS (stationary with stored position, e.g., recovery after power outage): <14 sec. (50%) <18 sec. (90%)
 Re-acquisition after 60-second signal loss: <2 sec. (90%)
 Dynamics
 Velocity 500 m/sec maximum
 Acceleration 4 g (39.2 m/sec²)
 Jerk 20 m/sec³

PPS output
 Physical Interface RS-422
 Width 10 microseconds (default); user-programmable from 10 microseconds to 500 milliseconds
 On-Time Edge Rising edge on-time (default); user-programmable rising or falling
 Resolution 80 nanoseconds (quantization error reported through TSIP)
 Accuracy (one sigma): UTC 15 nanoseconds (static) UTC 90 nanoseconds (dynamic, TDOP ≤3)
 External Event Capture
 Interface RS-422
 Resolution 488 nanoseconds
 Minimum pulse width 10 microsecond, rising edge on-time
 Reporting mechanism TSIP packet

ELECTRICAL SPECIFICATIONS

Prime power +5 V DC* to +36 V DC, reverse polarity protection
 Power consumption . 50 mA @ 12 volts, 0.6 watts (typical), <1 watt max
 * reduced cable length @ +5 V DC to +12 V DC

SERIAL PROTOCOLS

Port	Interface	Protocols	Defaults
TxB (primary)	RS-422	TSIP, NMEA	TSIP @ 9600, 8-odd-1
RxB (primary)	RS-422	TSIP	TSIP @ 9600, 8-odd-1
TxA (secondary)	RS-422	TSIP	TSIP @ 9600, 8-odd-1
RxA (secondary)	RS-422	Event	Event

All ports support baud rates of 4,800 – 115,200; 8 data bits; even, odd, no parity.
 NMEA messages: GGA, GLL, VTG, GSV, GSA, ZDA, RMC

ORDERING INFORMATION & ACCESSORIES

Please go to www.trimble.com/timing for the latest documentation & tools, part numbers and ordering information

Trimble has relied on representation made by its suppliers in certifying this product as RoHS compliant.
 Specifications subject to change without notice
 Trimble Navigation Limited is not responsible for the operation or failure of operation of GPS satellites or the availability of GPS satellite signals.

NORTH AMERICA
 Trimble Navigation Limited
 Corporate Headquarters
 935 Stewart Drive
 Sunnyvale, CA 94085
 Phone: +1-800-787-4225
 Phone: +1-408-481-7741
 Email: timing@trimble.com

EUROPE
 Trimble Navigation Europe
 Phone: +49-6142-2100-161

KOREA
 Trimble Export Ltd, Korea
 Phone: +82-2-555-5361

CHINA
 Trimble Navigation Ltd, China
 Phone: +86-21-6391-7814

TAIWAN
 Trimble Export Limited, Taiwan
 Phone: +886-02-85096574

